

# ***Werkzeughalter nach DIN 69 880 für CNC-Drehmaschinen***

***Tool Holder to  
DIN 69 880 For CNC Lathes***

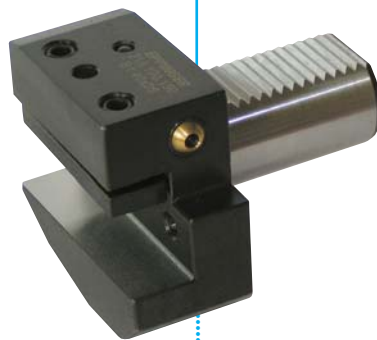

**EPPINGER**

# Technische Merkmale

## Technical Information

Die in DIN 69 880 genau definierten Werkzeughalter der verschiedenen Formen werden von Eppinger mit höchster Präzision gefertigt. Das DIN-Programm wird durch eine umfangreiche Palette von im harten Praxiseinsatz bewährten Sonderhaltern ergänzt.

Die besonderen technischen Merkmale des kompletten Eppinger-Programms sind:

- Jeder Halter komplett einsatzgehärtet.
- Oberflächenhärte 58 – 60 HRc.
- Kernfestigkeit über 1000 N/mm<sup>2</sup>
- Schaft, Kerbverzahnung, Anlagefläche, Fixierbohrung, Stahlauflege oder Aufnahmebohrung geschliffen.
- Jederzeit auf die nächst kleinere Drehmeißelhöhe nachrüstbar.
- Lage des Drehmeißels im Werkzeughalter über Anschlagsschrauben einstellbar.
- Federnde Druckplatten zur positionsgenauen Klemmung der Drehmeißel.
- Kühlmittelzufuhr über schnell und exakt einstellbare Kugeldüsen mit neuartiger Klemmung.
- Korrosionsfest gegen alle bekannten Kühl- und Schmiermittel.
- Keine Beschädigung der Oberfläche durch äussere Einflüsse.
- Entsprechend DIN 69 880 haben die Werkzeughalter am Schaft/Anlagefläche einen Einstich zur Aufnahme eines O-Rings.  
Der O-Ring gehört nicht zum Lieferumfang.  
Siehe Katalog Zubehör Seite Z 7.1











The various tool holder models defined in detail in DIN 69 880 are manufactured by Eppinger with ultimate precision. The DIN range is enhanced by a comprehensive line of special holders tried and tested under tough conditions.

The full Eppinger range has a number of special technical features:

- Each holder is fully case hardened.
- Surface hardness of 58 – 60 HRc.
- Core strength in excess of 1000 N/mm<sup>2</sup>
- Shaft, serration, seating face, locating bore, clamp plate or locator bore, are ground.
- Adjustable any time to the next lower cutter height.
- Position of cutter in tool holder adjustable using two stop screws.
- Spring-mounted pressure plates for clamping cutter in the exact position.
- Internal coolant supply through ball nozzles featuring quick and precise adjustment with new type of clamp fixture.
- Corrosion-resistant to all known coolants and lubricants.
- No surface damage due to external factors.
- As defined in DIN 69 880 the holders are equipped with an undercut at shaft/seating face to accommodate a sealing ring.  
The sealing ring is optional.  
See catalog accessories page Z 7.1

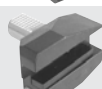
# Technische Merkmale

## Technical Information

Hauptspindel Main spindle	Über Mitte Over centre line				Unter Mitte Below centre line			
Drehrichtung der Hauptspindel Direction of rotation main spindle	M03		M04		M03		M04	
VDI-Form / VDI-type	Ober. Rev. Up. turret	Unt. Rev. Low. turret	Ober. Rev. Up. turret	Unt. Rev. Low. turret	Ober. Rev. Up. turret	Unt. Rev. Low. turret	Ober. Rev. Up. turret	Unt. Rev. Low. turret
<b>B1</b> 			X	X				
<b>B2</b> 					X	X		
<b>B3</b> 	X	X						
<b>B4</b> 							X	X
<b>B5</b> 			X	X				
<b>B6</b> 					X	X		
<b>B7</b> 	X	X						
<b>B8</b> 							X	X
<b>C1</b> 			X	X				
<b>C2</b> 					X	X		
<b>C3</b> 	X	X						
<b>C4</b> 							X	X

# Werkzeughalter *Inhaltsverzeichnis*

Tool holder · Index

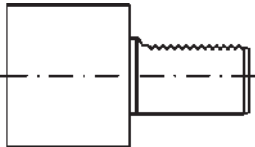
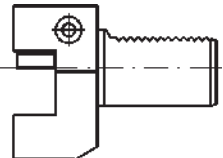
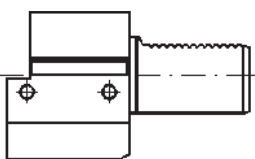
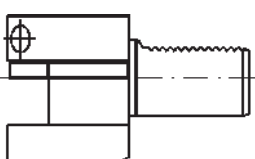
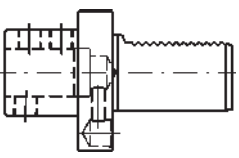

DIN 69 880

Übersicht / Overview	Gruppe Group	Beschreibung / Description
 <p>Werkzeughalter Sonderausführung</p> <p>Tool Holder Blank</p>	<p><b>V 1</b></p>	<p>V 1.1 Form A1 V 1.2 Form A2</p>
 <p>Vierkant- Queraufnahme</p> <p>Turning Tool Holder</p>	<p><b>V 2</b></p>	<p>V 2.1 Form B1    V 2.5 Form B5 V 2.2 Form B2    V 2.6 Form B6 V 2.3 Form B3    V 2.7 Form B7 V 2.4 Form B4    V 2.8 Form B8</p>
 <p>Vierkant- Längsaufnahme</p> <p>Turning Tool Holder For Square To</p>	<p><b>V 3</b></p>	<p>V 3.1 Form C1 V 3.2 Form C2 V 3.3 Form C3 V 3.4 Form C4</p>
 <p>Vierkant- Mehrfachaufnahme</p> <p>Multiple purposer Square Tool Holder</p>	<p><b>V 4</b></p>	<p>V 4.1 Form D1 V 4.2 Form D2</p>
 <p>Werkzeughalter für Wendeplattenbohrer</p> <p>Tool Holder For Carbide Indexable Drill</p>	<p><b>V 5</b></p>	<p>V 5.1 Form E1</p>

# Werkzeughalter Inhaltsverzeichnis

Tool holder · Index

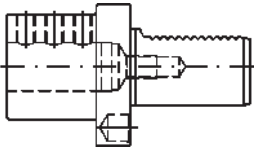
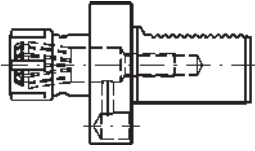
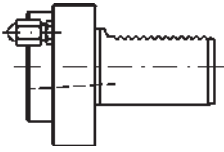
DIN 69 880

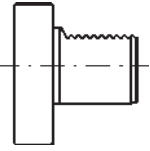
Übersicht / Overview	Gruppe Group	Beschreibung / Description
 <p>Bohrstangenaufnahme Boring Bar Holder</p>	<b>V 6</b>	V 6.1 Form E2 V 6.2 Bohrstangenaufnahme, axial versetzt
 <p>Spannzangenaufnahme Collet Chuck</p>	<b>V 7</b>	V 7.1 Form E3 DIN 6388 Ortlieb V 7.2 Form E3 DIN 6345 Rubber-Flex V 7.3 Form E4 DIN 6499 Schaublin V 7.4 Form E4 DIN 6499 Schaublin höhenverstellbar
 <p>Morsekegel- aufnahme Morse Taper Holder</p>	<b>V 8</b>	V 8.1 Form F1
 <p>Klemmring Clamping Ring</p>	<b>V 9</b>	V 9.1 Form Z1
 <p>Schutzstopfen Blanking Plug</p>	<b>V 10</b>	V 10.1 Form Z2

# Werkzeughalter Inhaltsverzeichnis

Tool holder · Index

DIN 69 880

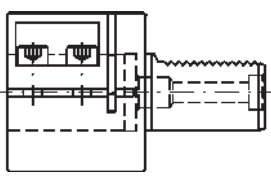
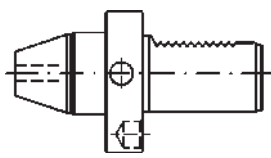
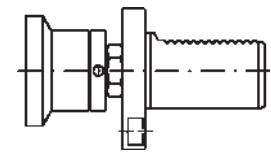
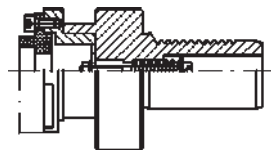
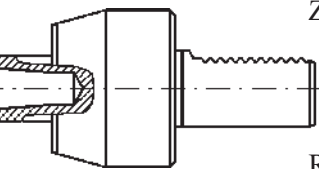
Übersicht / Overview	Gruppe Group	Beschreibung / Description
 <p>Bohrstangenhalter Boring Bar Holder</p>	<p><b>V 11</b></p>	<p>V 11.1 Bohrstangenhalter</p>
 <p>Kurzbohrfutter Short Drilling Chuck For Reversible Operation</p>	<p><b>V 12</b></p>	<p>V 12.1 Kurzbohrfutter</p>
 <p>Werkstoffanschlag mitlaufend Revolving Stock Stop</p>	<p><b>V 13</b></p>	<p>V 13.1 Werkstoffanschlag mitlaufend</p>
 <p>Schneideisenhalter Extendible Die Holder</p>	<p><b>V 14</b></p>	<p>V 14.1 Schneideisenhalter</p>
 <p>Zentrierspitze Revolving Center Point</p>	<p><b>V 15</b></p>	<p>V 15.1 Zentrierspitze, mitlaufend für Zentriereinsätze</p>

# Werkzeughalter Inhaltsverzeichnis

Tool holder · Index

DIN 69 880

Übersicht / Overview

**Gruppe  
Group**

Beschreibung / Description

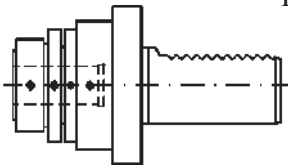

Pendelhalter

Floating Holder

**V 16**

V 16.1 Pendelhalter mit innerer Kühlmittelzufuhr  
V 16.2 Pendelhalter mit äusserer Kühlmittelzufuhr

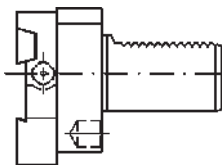

Abstechhalter

Cut-off Tool Holder

**V 17**

V 17.1 Abstechhalter höhenverstellbar

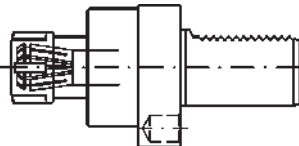

Gewindebohrhalter

Tap Holder

**V 18**

V 18.1 Gewindebohrhalter mit Längenausgleich auf Zug und Druck für Spannzangen nach DIN 6499

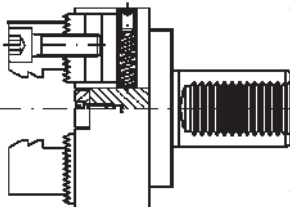

Greiferfutter

Bar Puller

**V 20**

V 20.1 Greiferfutter

**Werkzeughalter** *Inhaltsverzeichnis*

Tool holder · Index

DIN 69 880

Übersicht / Overview

**Gruppe**  
**Group**

Beschreibung / Description

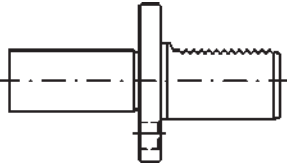

Prüfdorn

**V 21**

V 21.1 Prüfdorn

Test Mandrel



# Werkzeughalter für Sonderausführungen

## Form A1

Pre-machined blank (Tool holder for special design)

DIN 69 880

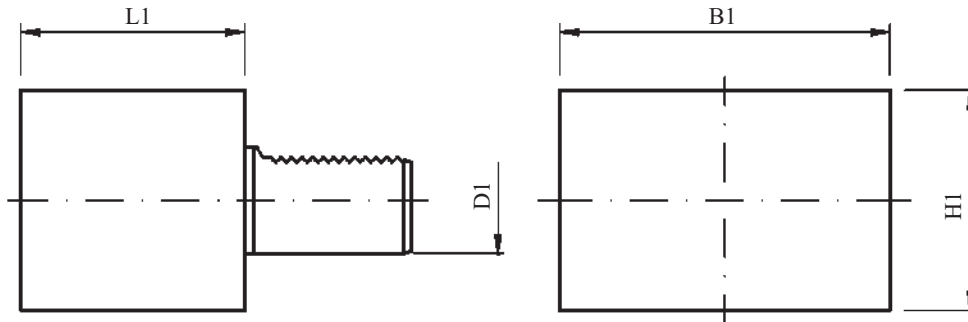

D1	DIN-Bezeichnung DIN-Designation	Artikel-Nr. Part No.	B1	H1	L1				
16	A1-16x44	200.075.150	78	44	44				
20	A1-20x65	201.075.150	100	60	65				
25	A1-25x75	207.075.150	100	60	75				
30	A1-30x85	202.075.150	130	76	85				
40	A1-40x100	203.075.150	151	96	100				
50	A1-50x125	204.075.150	160	120	125				
60	A1-60x160	205.075.150	165	125	160				

**Bemerkungen / Remarks:**

- ° Sonderabmessungen auf Anfrage
  - ° Special sizes on request
- Material: C45 / Material steel: C45

# Werkzeughalter für Sonderausführungen

## Form A2

Pre-machined blank (Tool holder for special design)

DIN 69 880

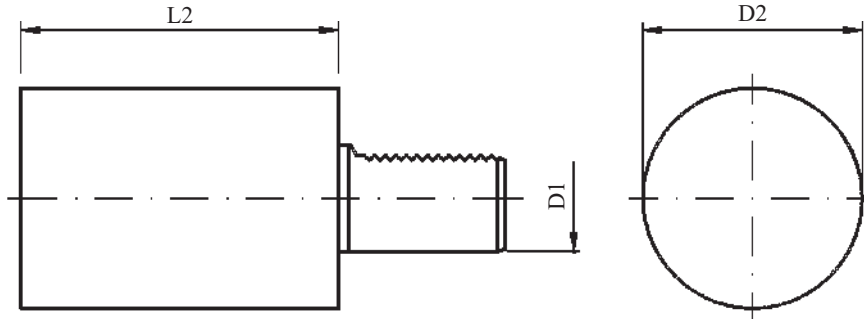

D1	DIN-Bezeichnung DIN-Designation	Artikel-Nr. Part No.	D2	L2				
16	A2-16x60	200.080.150	40	60				
20	A2-20x70	201.080.150	50	70				
25	A2-25x80	207.077.150	58	80				
25	A2-25x200	207.080.150	58	200				
30	A2-30x100	202.077.150	68	100				
30	A2-30x240	202.080.150	68	240				
40	A2-40x120	203.077.150	83	120				
40	A2-40x320	203.080.150	83	320				
50	A2-50x135	204.077.150	98	135				
50	A2-50x400	204.080.150	98	400				
60	A2-60x150	205.077.150	123	150				
60	A2-60x480	205.080.150	123	480				

**Bemerkungen / Remarks:**

- ° Sonderabmessungen auf Anfrage
  - ° Special sizes on request
- Material: C45 / Material steel: C45

**Vierkant-Queraufnahme** rechts, kurz

**Form B1**

Rectangular transverse tool holder, right hand, short

DIN 69 880

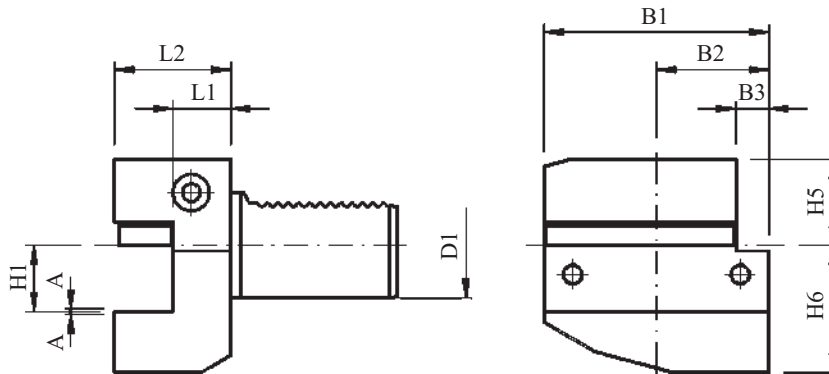

D1	H1 <sup>-0,1</sup>	DIN-Bezeichnung DIN-Designation	Artikel-Nr. Part No.	B1	B2	B3	H5	H6	L1 <sup>+0,5</sup>	L2	Unterlegplatte Adapter
16	12	B1-16x12x24	210.100.150	42	23	5	20	22	13	24	-
20	16	B1-20x16x30	211.102.150	55	30	7	25	30	16	30	218.329.220
20	16	B1-20x16x40	211.100.150	55	30	7	25	30	26	40	218.329.220
20	16	B1-20x16x30	231.102.150	55	30	7	25	30	18,5	30	218.329.220 *
20	16	B1-20x16x40	231.100.150	55	30	7	25	30	25,5	40	218.329.220 *
25	16	B1-25x16x30	217.100.150	55	30	7	25	30	16	30	218.329.220
30	20	B1-30x20x40	212.100.150	70	35	10	28	38	22	40	218.280.220
30	20	B1-30x20x60	212.102.150	70	35	10	28	38	42	60	218.280.220
30	20	B1-30x20x50	232.200.150	70	35	10	28	35	32	50	218.280.220 *
40	25	B1-40x25x44	213.100.150	85	42,5	12,5	32,5	48	22	44	218.286.220
50	32	B1-50x32x55	214.100.150	100	50	16	35	60	30	55	218.290.220
60	32	B1-60x32x60	215.100.150	125	62,5	16	42,5	62,5	30	60	218.031.220

Bemerkungen / Remarks:

\* höhenverstellbar / A=1 / height adjustable / A=1

**Unterlegplatten für kleinere Drehmeißel**

Adapter for smaller lathe chisel

Artikel-Nr. Part No.	H	L	B
218.329.220	4	54	14
218.280.220	4	69	16
218.286.220	5	84	20
218.290.220	7	99	25
218.031.220	7	120	25

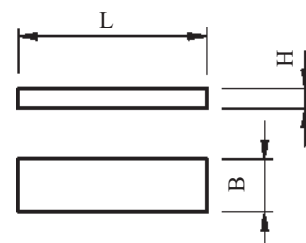

**Vierkant-Queraufnahme links, kurz**

**Form B2**

Rectangular transverse tool holder, left hand, short

DIN 69 880

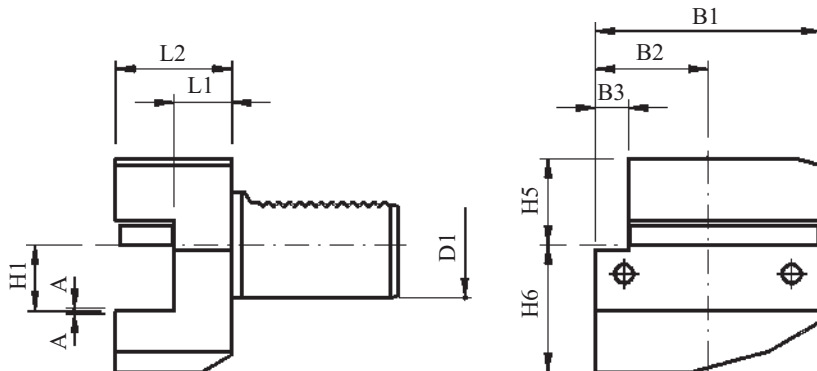

D1	H1 <sub>-0,1</sub>	DIN-Bezeichnung DIN-Designation	Artikel-Nr. Part No.	B1	B2	B3	H5	H6	L1 <sup>+0,5</sup>	L2	Unterlegplatte Adapter
16	12	B2-16x12x24	210.117.150	42	23	5	20	22	13	24	-
16	12	B2-16x12x34	210.115.150	42	23	5	20	22	23	34	-
20	16	B2-20x16x30	211.117.150	55	30	7	25	30	16	30	218.329.220
20	16	B2-20x16x30	231.117.150	55	30	7	25	30	18	30	218.275.220 *
20	16	B2-20x16x40	211.115.150	55	30	7	25	30	26	40	218.329.220
25	16	B2-25x16x30	217.115.150	55	30	7	25	30	16	30	218.329.220
25	16	B2-25x16x40	217.117.150	55	30	7	25	30	26	40	218.329.220
30	20	B2-30x20x40	212.115.150	70	35	10	28	38	22	40	218.280.220
30	20	B2-30x20x60	212.117.150	70	35	10	28	38	42	60	218.280.220
40	25	B2-40x25x44	213.115.150	85	42,5	12,5	32,5	48	22	44	218.286.220
50	32	B2-50x32x55	214.115.150	100	50	16	35	60	30	55	218.290.220
60	32	B2-60x32x60	215.115.150	125	62,5	16	42,5	62,5	30	60	218.031.220

**Bemerkungen / Remarks:**

\* höhenverstellbar / A=1 / height adjustable / A=1

**Unterlegplatten für kleinere Drehmeißel**

Adapter for smaller lathe chisel

Artikel-Nr. Part No.	H	L	B
218.329.220	4	54	14
218.275.220	4	55	12
218.280.220	4	69	16
218.286.220	5	84	20
218.290.220	7	99	25
218.031.220	7	120	25

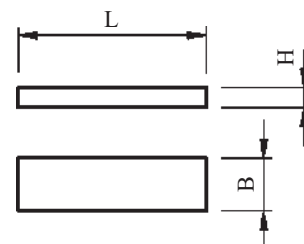

# Vierkant-Queraufnahme Überkopf rechts, kurz **Form B3**

Rectangular transverse tool holder, overhead right hand, short

DIN 69 880

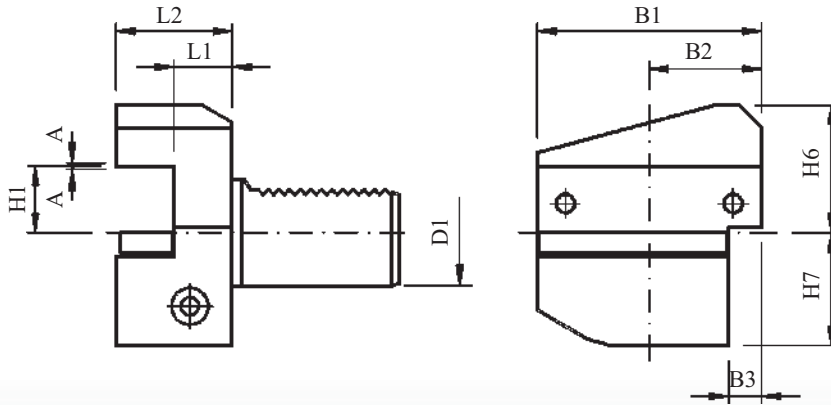

D1	H1 <sub>-0,1</sub>	DIN-Bezeichnung DIN-Designation	Artikel-Nr. Part No.	B1	B2	B3	H6	H7	L1 <sup>+0,5</sup>	L2	Unterlegplatte Adapter
16	12	B3-16x12x24	210.105.150	42	23	5	22	20	13	24	-
20	16	B3-20x16x30	211.107.150	55	30	7	30	25	16	30	218.329.220
20	16	B3-20x16x40	211.105.150	55	30	7	30	25	26	40	218.329.220
20	16	B3-20x16x30	231.107.150	55	30	7	30	25	18,5	30	218.329.220 *
20	16	B3-20x16x40	231.105.150	55	30	7	30	25	25,5	40	218.329.220 *
25	16	B3-25x16x30	217.105.150	55	30	7	30	25	16	30	218.329.220
30	20	B3-30x20x40	212.105.150	70	35	10	38	35	22	40	218.280.220
30	20	B3-30x20x60	212.107.150	70	35	10	38	35	42	60	218.280.220
40	25	B3-40x25x44	213.105.150	85	42,5	12,5	48	42,5	22	44	218.286.220
50	32	B3-50x32x55	214.105.150	100	50	16	60	50	30	55	218.290.220
60	32	B3-60x32x60	215.105.150	125	62,5	16	62,5	62,5	30	60	218.031.220

**Bemerkungen / Remarks:**

\* höhenverstellbar / A=1 / height adjustable / A=1

## Unterlegplatten für kleinere Drehmeißel

Adapter for smaller lathe chisel

Artikel-Nr. Part No.	H	L	B
218.329.220	4	54	14
218.280.220	4	69	16
218.286.220	5	84	20
218.290.220	7	99	25
218.031.220	7	120	25

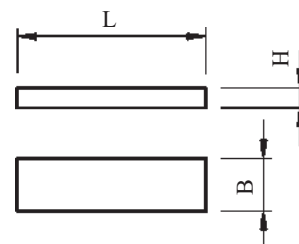

# Vierkant-Queraufnahme Überkopf links, kurz **Form B4**

Rectangular transverse tool holder, overhead left hand, short

DIN 69 880

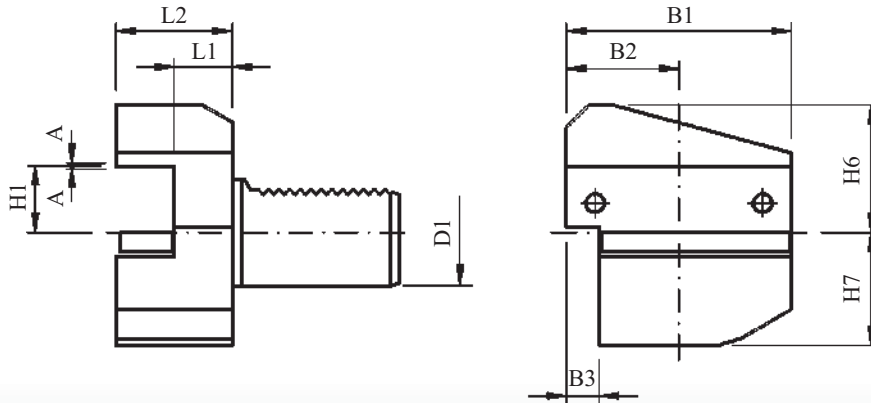

D1	H1 <sub>-0,1</sub>	DIN-Bezeichnung DIN-Designation	Artikel-Nr. Part No.	B1	B2	B3	H6	H7	L1 <sup>+0,5</sup>	L2	Unterlegplatte Adapter
20	16	B4-20x16x30	211.112.150	55	30	7	30	25	16	30	218.329.220
20	16	B4-20x16x40	211.110.150	55	30	7	30	25	26	40	218.329.220
20	16	B4-20x16x30	231.112.150	55	30	7	30	25	18,5	30	218.329.220 *
20	16	B4-20x16x40	231.110.150	55	30	7	30	25	25,5	40	218.329.220 *
25	16	B4-25x16x30	217.110.150	55	30	7	30	25	16	30	218.329.220
30	20	B4-30x20x40	212.110.150	70	35	10	38	35	22	40	218.280.220
30	20	B4-30x20x60	212.112.150	70	35	10	38	35	42	60	218.280.220
40	25	B4-40x25x44	213.110.150	85	42,5	12,5	48	42,5	22	44	218.286.220
50	32	B4-50x32x55	214.110.150	100	50	16	60	50	30	55	218.290.220
60	32	B4-60x32x60	215.110.150	125	62,5	16	62,5	62,5	30	60	218.031.220

**Bemerkungen / Remarks:**

\* höhenverstellbar / A=1 / height adjustable / A=1

## Unterlegplatten für kleinere Drehmeißel

Adapter for smaller lathe chisel

Artikel-Nr. Part No.	H	L	B
218.329.220	4	54	14
218.280.220	4	69	16
218.286.220	5	84	20
218.290.220	7	99	25
218.031.220	7	120	25

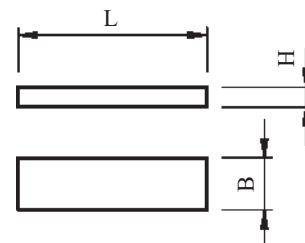

**Vierkant-Queraufnahme** rechts, lang

**Form B5**

Rectangular transverse tool holder, right hand, long

DIN 69 880

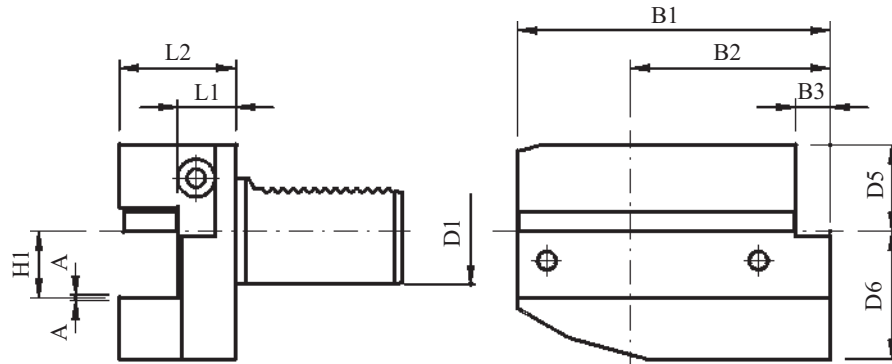

D1	H1 <sub>-0,1</sub>	DIN-Bezeichnung DIN-Designation	Artikel-Nr. Part No.	B1	B2	B3	H5	H6	L1 <sup>+0,5</sup>	L2	Unterlegplatte Adapter
20	16	B5-20x16x30	221.102.150	75	50	7	25	30	16	30	218.331.220
20	16	B5-20x16x40	221.100.150	75	50	7	25	30	26	40	218.331.220
20	16	B5-20x16x30	241.102.150	75	50	7	25	30	18	30	218.331.220 *
30	20	B5-30x20x40	222.100.150	100	65	10	28	38	22	40	218.281.220
30	20	B5-30x20x60	222.102.150	100	65	10	28	38	42	60	218.281.220
40	25	B5-40x25x44	223.100.150	118	75,5	12,5	32,5	48	22	44	218.288.220
50	32	B5-50x32x55	224.100.150	130	80	16	35	60	30	55	218.291.220
60	32	B5-60x32x60	225.100.150	145	82,5	16	42,5	62,5	30	60	218.349.220

**Bemerkungen / Remarks:**

\* höhenverstellbar / A=1 / height adjustable / A=1

**Unterlegplatten für kleinere Drehmeißel**

Adapter for smaller lathe chisel

Artikel-Nr. Part No.	H	L	B
218.331.220	4	73	14
218.281.220	4	99	16
218.288.220	5	117	20
218.291.220	7	129	25
218.349.220	7	143	25

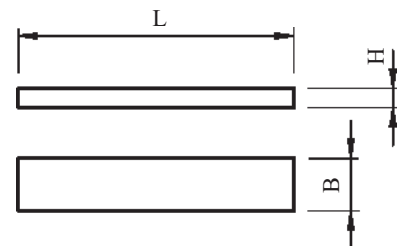

**Vierkant-Queraufnahme links, lang**

**Form B6**

Rectangular transverse tool holder, left hand, long

DIN 69 880

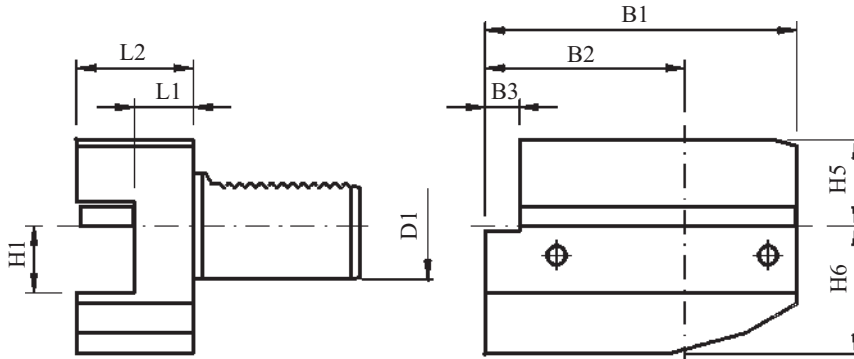

D1	H1 <sub>-0,1</sub>	DIN-Bezeichnung DIN-Designation	Artikel-Nr. Part No.	B1	B2	B3	H5	H6	L1 <sup>+0,5</sup>	L2	Unterlegplatte Adapter
20	16	B6-20x16x30	221.117.150	75	50	7	25	30	16	30	218.331.220
20	16	B6-20x16x40	221.115.150	75	50	7	25	30	26	40	218.331.220
30	20	B6-30x20x40	222.115.150	100	65	10	28	38	22	40	218.281.220
30	20	B6-30x20x60	222.117.150	100	65	10	28	38	42	60	218.281.220
40	25	B6-40x25x44	223.115.150	118	75,5	12,5	32,5	48	22	44	218.288.220
50	32	B6-50x32x55	224.115.150	130	80	16	35	60	30	55	218.291.220
60	32	B6-60x32x60	225.115.150	145	82,5	16	42,5	62,5	30	60	218.349.220

**Unterlegplatten für kleinere Drehmeißel**

Adapter for smaller lathe chisel

Artikel-Nr. Part No.	H	L	B
218.331.220	4	73	14
218.281.220	4	99	16
218.288.220	5	117	20
218.291.220	7	129	25
218.349.220	7	143	25

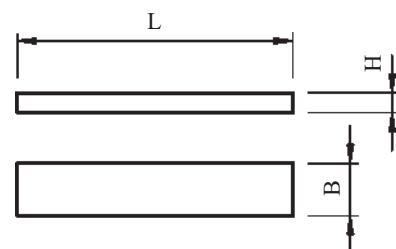



# Vierkant-Queraufnahme Überkopf rechts, lang **Form B7**

Rectangular transverse tool holder, overhead right hand, long

DIN 69 880

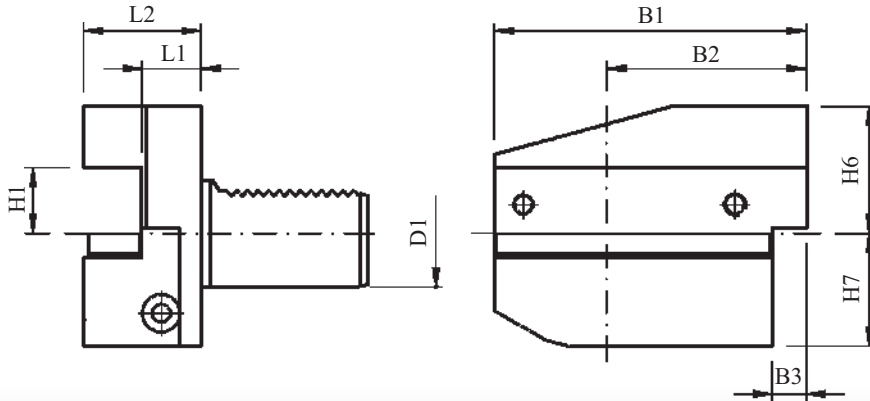

D1	H1 <sup>-0,1</sup>	DIN-Bezeichnung DIN-Designation	Artikel-Nr. Part No.	B1	B2	B3	H6	H7	L1 <sup>+0,5</sup>	L2	Unterlegplatte Adapter	
20	16	B7-20x16x30	221.107.150	75	50	7	30	25	16	30	218.331.220	
20	16	B7-20x16x40	221.105.150	75	50	7	30	25	26	40	218.331.220	
20	16	B7-20x16x30	241.107.150	75	50	7	30	25	18	30	218.331.220	*
30	20	B7-30x20x40	222.105.150	100	65	10	38	35	22	40	218.281.220	
30	20	B7-30x20x60	222.107.150	100	65	10	38	35	42	60	218.281.220	
40	25	B7-40x25x44	223.105.150	118	75,5	12,5	48	42,5	22	44	218.288.220	
50	32	B7-50x32x55	224.105.150	130	80	16	60	50	30	55	218.291.220	
60	32	B7-60x32x60	225.105.150	145	82,5	16	62,5	62,5	30	60	218.349.220	

**Bemerkungen / Remarks:**

\* höhenverstellbar / A=1 / height adjustable / A=1

## Unterlegplatten für kleinere Drehmeißel

Adapter for smaller lathe chisel

Artikel-Nr. Part No.	H	L	B
218.331.220	4	73	14
218.281.220	4	99	16
218.288.220	5	117	20
218.291.220	7	129	25
218.349.220	7	143	25

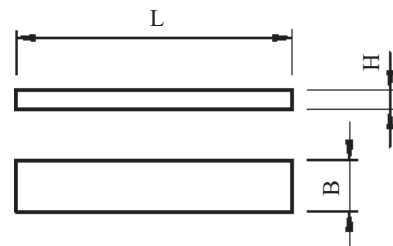

**Vierkant-Queraufnahme Überkopf links, lang Form B8**

Rectangular transverse tool holder, overhead left hand, long

DIN 69 880

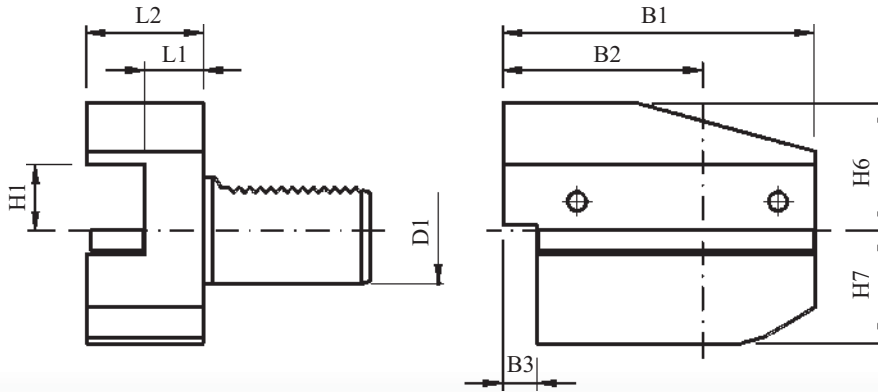

D1	H1 <sub>-0,1</sub>	DIN-Bezeichnung DIN-Designation	Artikel-Nr. Part No.	B1	B2	B3	H6	H7	L1 <sup>+0,5</sup>	L2	Unterlegplatte Adapter
20	16	B8-20x16x30	221.112.150	75	50	7	30	25	16	30	218.331.220
20	16	B8-20x16x40	221.110.150	75	50	7	30	25	26	40	218.331.220
30	20	B8-30x20x40	222.110.150	100	65	10	38	35	22	40	218.281.220
30	20	B8-30x20x60	222.112.150	100	65	10	38	35	42	60	218.281.220
40	25	B8-40x25x44	223.110.150	118	75,5	12,5	48	42,5	22	44	218.288.220
50	32	B8-50x32x55	224.110.150	130	80	16	60	50	30	55	218.291.220
60	32	B8-60x32x60	225.110.150	145	82,5	16	62,5	62,5	30	60	218.349.220

**Unterlegplatten für kleinere Drehmeißel**

Adapter for smaller lathe chisel

Artikel-Nr. Part No.	H	L	B
218.331.220	4	73	14
218.281.220	4	99	16
218.288.220	5	117	20
218.291.220	7	129	25
218.349.220	7	143	25

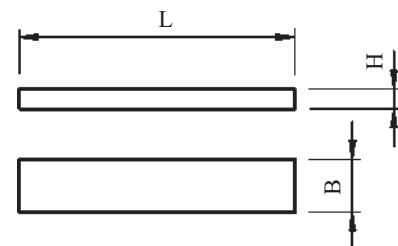

**Vierkant-Längsaufnahme rechts**

**Form C1**

Rectangular lengthwise tool holder, right hand

DIN 69 880

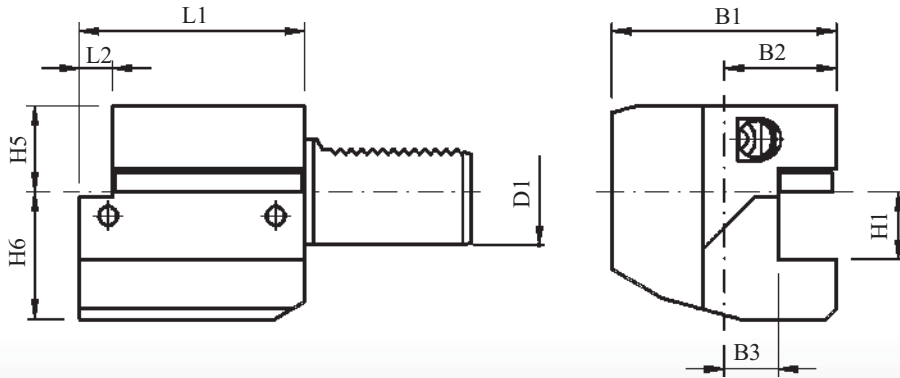

D1	H1 <sub>-0,1</sub>	DIN-Bezeichnung DIN-Designation	Artikel-Nr. Part No.	B1	B2	B3 <sup>+0,5</sup>	H5	H6	L1	L2	Unterlegplatte Adapter	
16	12	C1-16x12	210.120.150	43	24	13	20	22	44	5	-	
20	16	C1-20x16	211.122.150	52	27	13	25	30	55	7	218.329.220	
20	16	C1-20x16	211.120.150	65	40	26	25	30	50	-	218.330.220	
20	16	C1-20x16	231.120.150	65	40	25,5	25	30	50	-	218.328.220	*
25	16	C1-25x16	217.120.150	58	33	19	25	30	55	7	218.329.220	
30	20	C1-30x20	212.120.150	70	35	17	28	38	70	10	218.280.220	
40	25	C1-40x25	213.120.150	85	42,5	20,5	32,5	48	85	12,5	218.286.220	
50	32	C1-50x32	214.120.150	100	50	25,5	35	60	100	16	218.290.220	
60	32	C1-60x32	215.120.150	125	62,5	32,5	42,5	62,5	125	16	218.031.220	

**Bemerkungen / Remarks:**

\* höhenverstellbar / A=1 / height adjustable / A=1

**Unterlegplatten für kleinere Drehmeißel**

Adapter for smaller lathe chisel

Artikel-Nr. Part No.	H	L	B
218.330.220	4	48	14
218.329.220	4	54	14
218.280.220	4	69	16
218.286.220	5	84	20
218.290.220	7	99	25
218.031.220	7	120	25

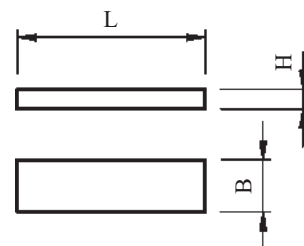

**Vierkant-Längsaufnahme links**

**Form C2**

Rectangular lengthwise tool holder, left hand

DIN 69 880

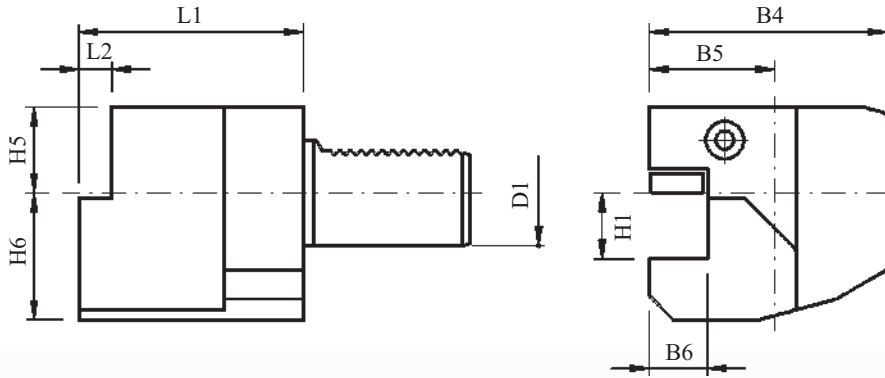

D1	H1 <sub>-0,1</sub>	DIN-Bezeichnung DIN-Designation	Artikel-Nr. Part No.	B4	B5	B6 <sup>+0,5</sup>	H5	H6	L1	L2	Unterlegplatte Adapter
20	16	C2-20x16	221.125.150	65	40	26	25	30	50	-	218.330.220
25	16	C2-25x16	227.125.150	58	33	19	25	30	55	7	218.329.220
30	20	C2-30x20	222.125.150	76	41	23	28	38	70	10	218.280.220
40	25	C2-40x25	223.125.150	90	47,5	25,5	32,5	48	85	12,5	218.286.220
50	32	C2-50x32	224.125.150	105	55	30,5	35	60	100	16	218.290.220
60	32	C2-60x32	225.125.150	125	62,5	32,5	42,5	62,5	125	16	218.031.220

**Unterlegplatten für kleinere Drehmeißel**

Adapter for smaller lathe chisel

Artikel-Nr. Part No.	H	L	B
218.330.220	4	48	14
218.329.220	4	54	14
218.280.220	4	69	16
218.286.220	5	84	20
218.290.220	7	99	25
218.031.220	7	120	25

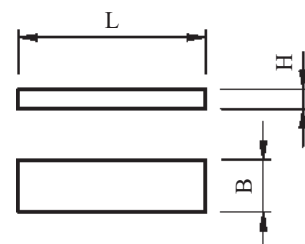

**Vierkant-Längsaufnahme Überkopf rechts Form C3**

Rectangular lengthwise tool holder, overhead right hand

DIN 69 880

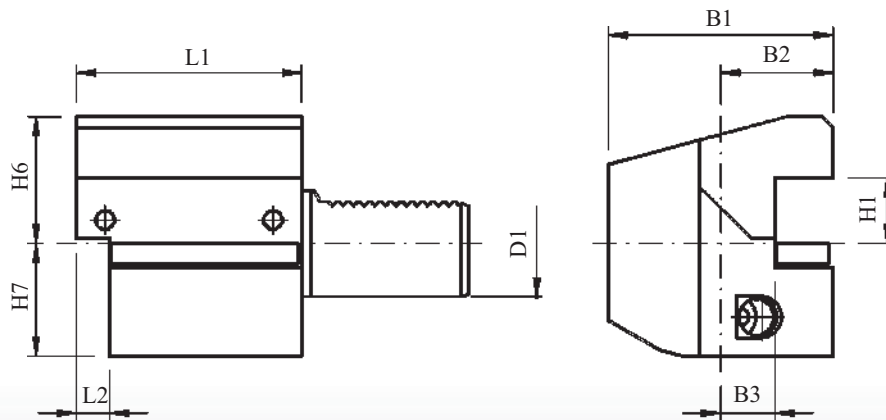

D1	H1 <sub>-0,1</sub>	DIN-Bezeichnung DIN-Designation	Artikel-Nr. Part No.	B1	B2	B3 <sup>+0,5</sup>	H6	H7	L1	L2	Unterlegplatte Adapter
16	12	C3-16x12	210.125.150	43	24	13	22	20	44	5	-
20	16	C3-20x16	211.127.150	52	27	13	30	25	55	7	218.329.220
20	16	C3-20x16	211.125.150	65	40	26	30	25	50	-	218.330.220
20	16	C3-20x16	231.125.150	65	40	26	30	25	50	-	218.328.220 *
25	16	C3-25x16	217.125.150	58	33	19	30	25	55	7	218.329.220
30	20	C3-30x20	212.125.150	70	35	17	38	35	70	10	218.280.220
40	25	C3-40x25	213.125.150	85	42,5	20,5	48	42,5	85	12,5	218.286.220
50	32	C3-50x32	214.125.150	100	50	25,5	60	50	100	16	218.290.220
60	32	C3-60x32	215.125.150	125	62,5	32,5	62,5	62,5	125	16	218.031.220

**Bemerkungen / Remarks:**

\* höhenverstellbar / A=1 / height adjustable / A=1

**Unterlegplatten für kleinere Drehmeißel**

Adapter for smaller lathe chisel

Artikel-Nr. Part No.	H	L	B
218.330.220	4	48	14
218.329.220	4	54	14
218.280.220	4	69	16
218.286.220	5	84	20
218.290.220	7	99	25
218.031.220	7	120	25

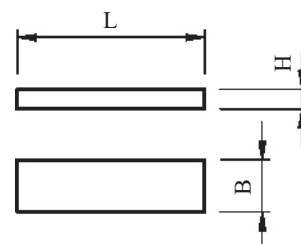

**Vierkant-Längsaufnahme Überkopf links**

**Form C4**

Rectangular lengthwise tool holder, overhead left hand

DIN 69 880

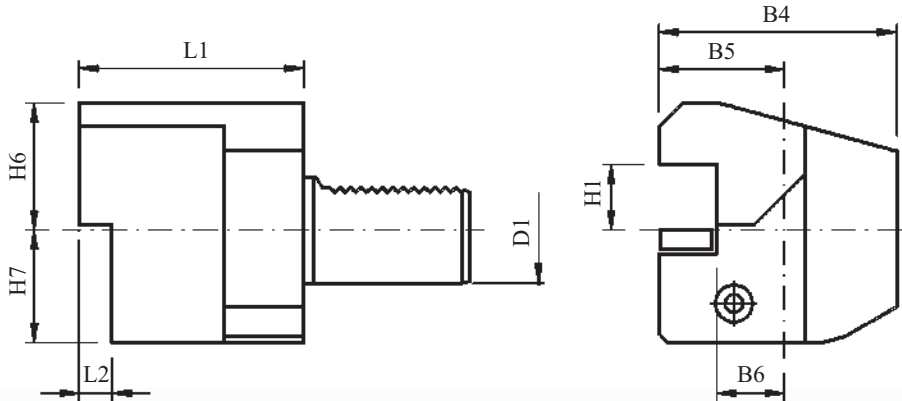

D1	H1 <sub>-0,1</sub>	DIN-Bezeichnung DIN-Designation	Artikel-Nr. Part No.	B4	B5	B6 <sup>+0,5</sup>	H6	H7	L1	L2	Unterlegplatte Adapter
20	16	C4-20x16	221.120.150	65	40	26	30	25	50	-	218.330.220
25	16	C4-25x16	227.120.150	58	33	19	30	25	55	7	218.329.220
30	20	C4-30x20	222.120.150	76	41	23	38	35	70	10	218.280.220
40	25	C4-40x25	223.120.150	90	47,5	25,5	48	42,5	85	12,5	218.286.220
50	32	C4-50x32	224.120.150	105	55	30,5	60	50	100	16	218.290.220
60	32	C4-60x32	225.120.150	125	62,5	32,5	62,5	62,5	125	16	218.031.220

**Unterlegplatten für kleinere Drehmeißel**

Adapter for smaller lathe chisel

Artikel-Nr. Part No.	H	L	B
218.330.220	4	48	14
218.329.220	4	54	14
218.280.220	4	69	16
218.286.220	5	84	20
218.290.220	7	99	25
218.031.220	7	120	25

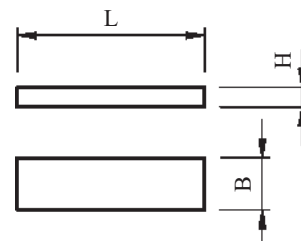

# Vierkant-Mehrfachaufnahme

# Form D1

Rectangular tool holder with multiple seats

DIN 69 880

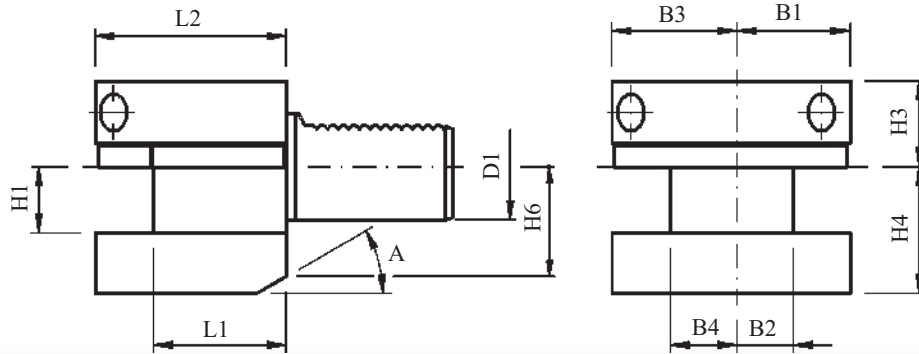

D1	H1 <sub>-0,1</sub>	DIN-Bezeichnung DIN-Designation	Artikel-Nr. Part No.	B1	B2 <sup>+0,3</sup>	B3	B4 <sup>+0,3</sup>	H3	H4	H6	L1 <sup>+0,5</sup>	L2	A
25	16	D1-25x16	217.135.150	33	19	33	19	22	30	25	34	48	30
30	20	D1-30x20	212.135.150	35	17	41	23	28	38	30	42	60	25
40	25	D1-40x25	213.135.150	42,5	20,5	47,5	25,5	32,5	48	-	50	72	-
50	32	D1-50x32	214.135.150	50	25,5	55	30,5	35	60	-	60	85	-
60	32	D1-60x32	215.135.150	57,5	32,5	57,5	32,5	42,5	62,5	-	85	110	-

**Vierkant-Mehrfachaufnahme Überkopf Form D2**

Rectangular tool holder with multiple seats, overhead

DIN 69 880

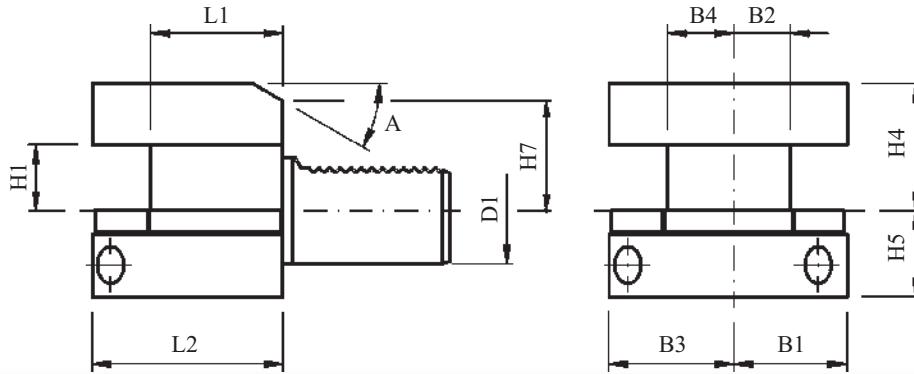

D1	H1 <sub>-0,1</sub>	DIN-Bezeichnung DIN-Designation	Artikel-Nr. Part No.	B1	B2 <sup>+0,3</sup>	B3	B4 <sup>+0,3</sup>	H4	H5	H7	L1 <sup>+0,5</sup>	L2	A
25	16	D2-25x16	217.140.150	33	19	33	19	30	25	25	34	48	30
30	20	D2-30x20	212.140.150	35	17	41	23	38	35	28	42	60	25
40	25	D2-40x25	213.140.150	42,5	20,5	47,5	25,5	48	42,5	-	50	72	-
50	32	D2-50x32	214.140.150	50	25,5	55	30,5	60	50	-	60	85	-
60	32	D2-60x32	215.140.150	57,5	32,5	57,5	32,5	62,5	62,5	-	85	110	-



# Werkzeughalter für Wendeplattenbohrer mit innerer Kühlmittelzufuhr **Form E1**

Tool holder for carbide indexable drill with internal coolant supply

**DIN 69 880**

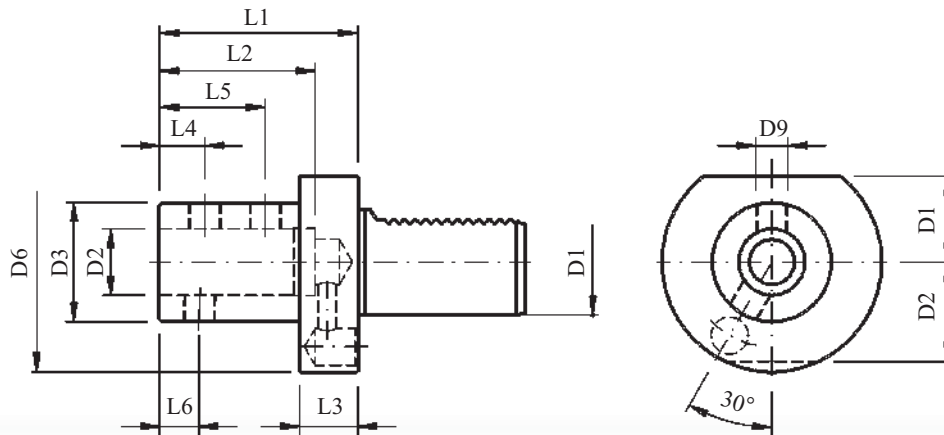

D1	D2 <sup>H6</sup>	DIN-Bezeichnung DIN-Designation	Artikel-Nr. Part No.	D3	D6	H1	H2	L1 <sub>±0,2</sub>	L2	L3	L4	L5	L6	Spannschrauben* Screws*	D9
20	16	E1-20x16	221.048.220	36	50	23	23	64	51	18	17	-	17	218.402.220	M10x1x11
20	20	E1-20x20	221.050.150	40	50	23	23	67	54	18	15	35	13	218.402.220	M10x1x11
20	25	E1-20x25	221.052.150	45	50	23	23	71	59	18	17	40	17	218.314.220	M12x1x12
25	16	E1-25x16	227.048.150	36	58	25	25	67	54	18	15	35	17	218.402.220	M10x1x11
25	20	E1-25x20	227.050.150	40	58	25	25	67	54	18	15	35	13	218.402.220	M10x1x11
25	25	E1-25x25	227.052.150	45	58	25	25	71	59	18	17	40	17	218.314.220	M12x1x12
30	16	E1-30x16	222.048.220	36	68	28	30	64	51	22	17	-	17	218.402.220	M10x1x11
30	20	E1-30x20	222.050.150	40	68	28	30	67	54	22	15	35	13	218.402.220	M10x1x11
30	25	E1-30x25	222.052.150	45	68	28	30	71	59	22	17	40	15	218.314.220	M12x1x12
30	32	E1-30x32	222.055.150	52	68	28	30	75	63	22	17	44	16	218.314.220	M12x1x12
30	40	E1-30x40	222.060.220	60	68	28	30	87	73	22	22	50	17	218.405.220	M16x1x13
40	16	E1-40x16	223.048.220	36	83	32,5	-	64	51	22	17	-	17	218.402.220	M10x1x11
40	20	E1-40x20	223.050.150	40	83	32,5	-	67	54	22	15	35	13	218.402.220	M10x1x11
40	25	E1-40x25	223.052.150	45	83	32,5	-	75	59	22	17	40	15	218.314.220	M12x1x12
40	32	E1-40x32	223.055.150	52	83	32,5	-	75	63	22	17	44	16	218.314.220	M12x1x12
40	40	E1-40x40	223.060.150	60	83	32,5	-	90	73	22	22	50	17	218.402.220	M10x1x11
50	20	E1-50x20	224.050.150	40	98	35	-	67	54	30	15	35	13	218.402.220	M10x1x11
50	25	E1-50x25	224.052.150	45	98	35	-	80	59	30	17	40	15	218.314.220	M12x1x12
50	32	E1-50x32	224.055.150	52	98	35	-	80	63	30	17	44	16	218.314.220	M12x1x12
50	40	E1-50x40	224.060.150	60	98	35	-	90	73	30	22	50	17	218.405.220	M16x1x13
50	50	E1-50x50	224.065.150	70	98	35	-	100	83	30	24	60	-	218.405.220	M16x1x13
60	20	E1-60x20	225.050.150	40	123	42,5	-	80	54	30	15	35	13	218.402.220	M10x1x11
60	25	E1-60x25	225.052.150	45	123	42,5	-	80	59	30	17	40	15	218.314.220	M12x1x12
60	32	E1-60x32	225.055.150	52	123	42,5	-	80	63	30	17	44	16	218.314.220	M12x1x12
60	40	E1-60x40	225.060.150	60	123	42,5	-	90	73	30	22	50	17	218.405.220	M16x1x13
60	50	E1-60x50	225.065.150	70	123	42,5	-	100	83	30	24	60	-	218.405.220	M16x1x13

Bemerkungen / Remarks: \* Ersatzteil / \* Spare part

**Bohrstangenaufnahme**  
mit äusserer und innerer Kühlmittelzufuhr

**Form E2**

Boring bar holder with external and internal coolant supply

DIN 69 880

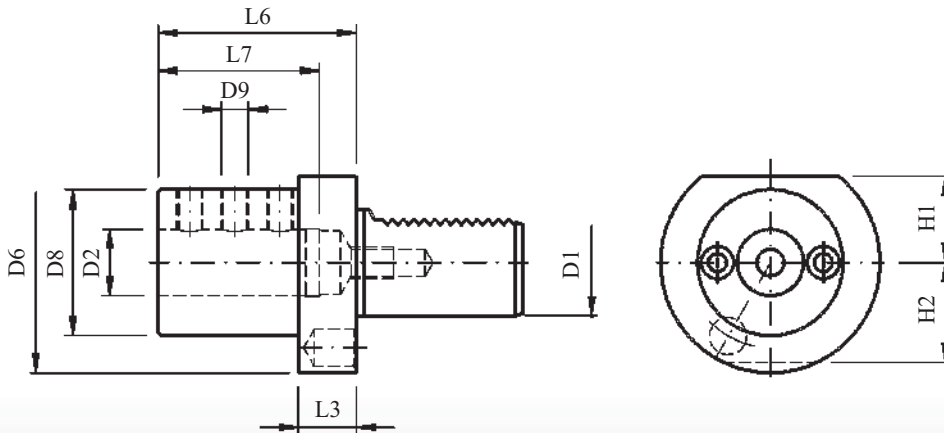

D1	D2 <sup>H7</sup>	DIN-Bezeichnung DIN-Designation	Artikel-Nr. Part No.	D6	D8	H1	H2	L3	L6	L7	Spannschrauben* Screws*	D9	
16	6	E2-16x6	200.015.149	40	32	18	18	13	44	34	10817	M6x12	
16	8	E2-16x8	200.015.150	40	32	18	18	13	44	34	10817	M6x12	
16	10	E2-16x10	200.015.151	40	32	18	18	13	44	34	10817	M6x12	
16	12	E2-16x12	200.015.152	40	40	18	18	13	44	34	10823	M8x12	
16	16	E2-16x16	200.015.153	40	40	18	18	13	44	34	10823	M8x12	
20	8	E2-20x8	201.010.150	50	40	23	23	18	50	41	10818	M6x16	
20	10	E2-20x10	201.010.151	50	40	23	23	18	50	41	10824	M8x16	
20	12	E2-20x12	201.010.152	50	40	23	23	18	50	41	10824	M8x16	
20	16	E2-20x16	201.010.153	50	40	23	23	18	50	41	10823	M8x12	
20	20	E2-20x20	201.010.154	50	50	23	23	18	50	41	10823	M8x12	
20	25	E2-20x25	201.010.155	50	50	23	23	18	60	51	10822	M8x10	
20	16	E2-20x16	231.010.163	50	-	-	-	-	40	27	10757	M6x20	**
25	8	E2-25x8	217.015.150	58	40	25	25	18	50	41	10820	M6x25	
25	10	E2-25x10	217.015.151	58	40	25	25	18	50	41	10820	M6x25	
25	12	E2-25x12	217.015.152	58	40	25	25	18	50	41	10824	M8x16	
25	16	E2-25x16	217.015.153	58	40	25	25	18	50	41	10824	M8x16	
25	20	E2-25x20	217.015.154	58	58	25	25	18	50	41	10824	M8x16	
25	25	E2-25x25	217.015.155	58	58	25	25	18	60	51	10824	M8x16	
30	8	E2-30x8	212.015.150	68	55	28	30	22	60	51	10820	M6x25	
30	10	E2-30x10	212.015.151	68	55	28	30	22	60	51	10820	M6x25	
30	12	E2-30x12	212.015.152	68	55	28	30	22	60	51	10825	M8x20	
30	16	E2-30x16	212.015.153	68	55	28	30	22	60	51	10825	M8x20	
30	20	E2-30x20	212.015.154	68	55	28	30	22	60	51	10825	M8x20	
30	25	E2-30x25	212.015.155	68	55	28	30	22	60	51	10824	M8x16	
30	30	E2-30x30	212.015.156	68	68	28	30	22	75	61	10824	M8x16	
30	32	E2-30x32	212.015.157	68	68	28	30	22	75	61	10824	M8x16	

Bemerkungen / Remarks: \* Ersatzteil \*\* höhen- und seitenverstellbar / \* Spare part \*\* height and side adjustable

# Bohrstangenaufnahme

mit äusserer und innerer Kühlmittelzufuhr

## Form E2

Boring bar holder with external and internal coolant supply

DIN 69 880

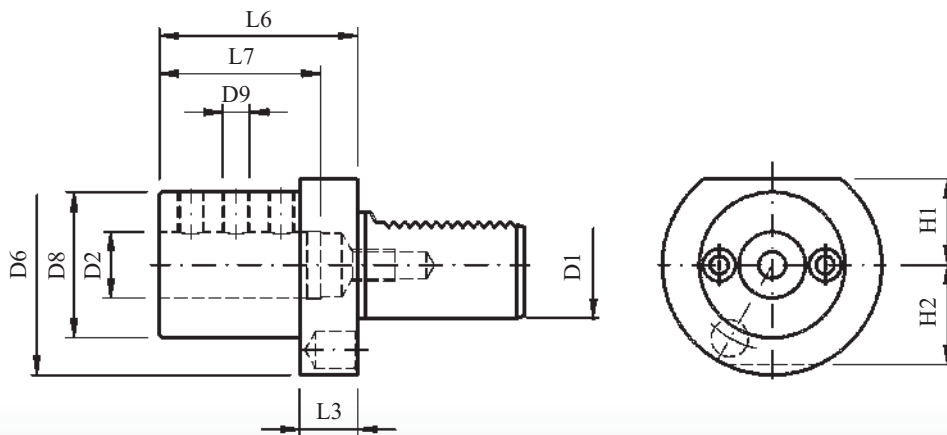

D1	D2 <sup>H7</sup>	DIN-Bezeichnung DIN-Designation	Artikel-Nr. Part No.	D6	D8	H1	H2	L3	L6	L7	Spannschrauben* Screws*	D9
40	8	E2-40x8	213.015.150	83	55	32,5	-	22	75	61	10826	M8x25
40	10	E2-40x10	213.015.151	83	55	32,5	-	22	75	61	10826	M8x25
40	12	E2-40x12	213.015.152	83	55	32,5	-	22	75	61	10826	M8x25
40	16	E2-40x16	213.015.153	83	55	32,5	-	22	75	61	10835	M10x25
40	20	E2-40x20	213.015.154	83	55	32,5	-	22	75	61	10834	M10x20
40	25	E2-40x25	213.015.155	83	55	32,5	-	22	75	61	10834	M10x20
40	30	E2-40x30	213.015.156	83	83	32,5	-	22	75	61	10834	M10x20
40	32	E2-40x32	213.015.157	83	83	32,5	-	22	75	61	10834	M10x20
40	40	E2-40x40	213.015.158	83	83	32,5	-	20	90	76	10774	M10x16
50	12	E2-50x12	214.015.152	98	68	35	-	30	90	76	10827	M8x30
50	16	E2-50x16	214.015.153	98	68	35	-	30	90	76	10777	M10x30
50	20	E2-50x20	214.015.154	98	68	35	-	30	90	76	10783	M12x25
50	25	E2-50x25	214.015.155	98	68	35	-	30	90	76	10783	M12x25
50	30	E2-50x30	214.015.156	98	68	35	-	30	90	76	10782	M12x20
50	32	E2-50x32	214.015.157	98	68	35	-	30	90	76	10782	M12x20
50	40	E2-50x40	214.015.158	98	98	35	-	30	90	76	10781	M12x16
50	50	E2-50x50	214.015.159	98	98	35	-	30	100	86	10780	M12x12
60	16	E2-60x16	215.015.153	123	68	42,5	-	30	90	76	10777	M10x30
60	20	E2-60x20	215.015.154	123	68	42,5	-	30	90	76	10783	M12x25
60	25	E2-60x25	215.015.155	123	68	42,5	-	30	90	76	10783	M12x25
60	30	E2-60x30	215.015.156	123	68	42,5	-	30	90	76	10782	M12x20
60	32	E2-60x32	215.015.157	123	68	42,5	-	30	90	76	10782	M12x20
60	40	E2-60x40	215.015.158	123	98	42,5	-	30	90	76	10782	M12x20
60	50	E2-60x50	215.015.159	123	98	42,5	-	30	100	86	10781	M12x16

Bemerkungen / Remarks: \* Ersatzteil / \* Spare part

# Bohrstangenaufnahme rechts, axial versetzt

Boring bar holder, right hand, offset

DIN 69 880

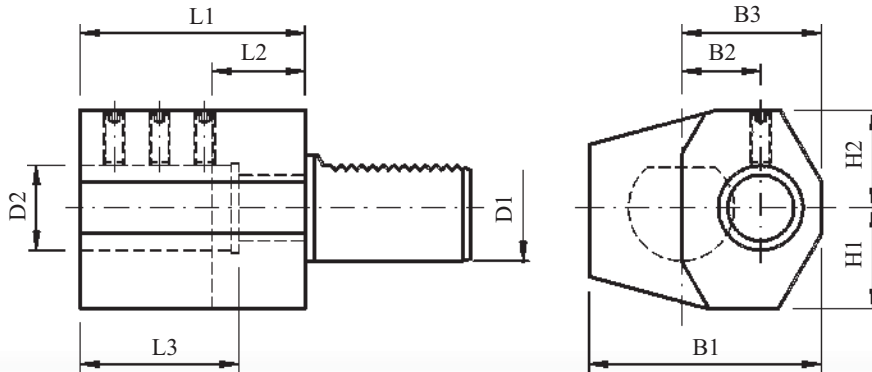

D1	D2 <sup>H7</sup>	Artikel-Nr. Part No.		B1	B2	B3	H1	H2	L1	L2	L3
30	20	7.030.084		88	30	53	37	38	71	35	45
30	25	7.030.085		88	30	53	37	38	71	35	45
30	32	7.030.086		88	30	53	37	38	85	35	60
40	32	320170	*	77,5	25	47,5	32	38	60	25	50

Bemerkungen / Remarks: \* Darstellung stimmt mit Werkzeug nicht überein / \* Drawing not correspondant with tool

## Reduzierbuchsen

### Bushing

Für Wkz.-Nr. For tool No.	212.015.157 213.015.157	213.015.158 214.015.158 215.015.158	214.015.159 215.015.159	7.030.086
A <sub>h6</sub>	32	40	50	32
L	60	75	85	60
B <sup>H6</sup>	Artikel-Nr. Part No.	Artikel-Nr. Part No.	Artikel-Nr. Part No.	Artikel-Nr. Part No.
6	218.858.220	-	-	218.858.220
8	218.862.220	218.868.220	-	218.862.220
10	218.863.220	218.869.220	218.883.220	218.863.220
12	218.864.220	218.870.220	218.884.220	218.864.220
16	218.865.220	218.871.220	218.885.220	218.865.220
20	218.866.220	218.872.220	218.886.220	218.866.220
25	218.867.220	218.873.220	218.887.220	218.867.220
32	-	218.874.220	218.888.220	-
40	-	-	218.877.220	-

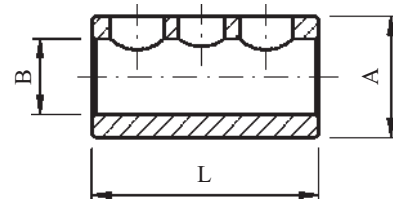

## Spannzangenaufnahme für Spannzangen nach DIN 6388 Ortlieb

### Form E3

Collet chuck

DIN 69 880

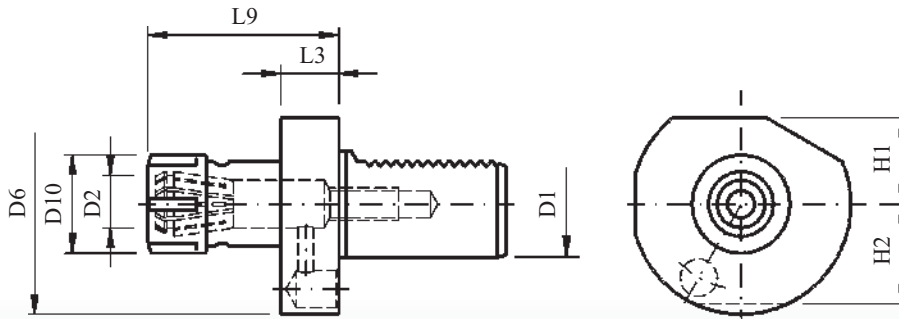

D1	D2	DIN-Bezeichnung DIN-Designation	Artikel-Nr. Part No.	D6	D10 max.	H1	H2	L3	L9 max.	Spannzangen collets	Rohrverschr. Coolant tubes
20	2-16	E3-20x16	221.010.150	50	43	23	23	18	57	NG 16	218.468.220
20	2-20	E3-20x20	221.020.150	50	50	23	23	18	62	NG 20	218.468.220
25	2-16	E3-25x16	227.005.150	58	43	25	25	18	57	NG 16	-
30	2-16	E3-30x16	222.005.150	68	43	28	30	22	57	NG 16	218.460.220
30	2-25	E3-30x25	222.010.150	68	60	28	30	22	75	NG 25	218.460.220
40	2-25	E3-40x25	223.005.150	83	60	32,5	-	22	75	NG 25	218.460.220
40	4-32	E3-40x32	223.010.150	83	72	32,5	-	22	90	NG 32	218.460.220
50	2-25	E3-50x25	224.005.150	98	60	35	-	30	75	NG 25	218.460.220
50	4-32	E3-50x32	224.010.150	98	72	35	-	30	90	NG 32	218.460.220
60	4-32	E3-60x32	225.005.150	123	72	42,5	-	30	90	NG 32	218.460.220
60	7,5-40	E3-60x40	225.010.150	123	85	42,5	-	30	100	NG 40	218.460.220

#### Bemerkungen:

Kühlmittelzufuhr durch Spannzange.  
Spannmutter und Dichtringe für Werkzeuge mit innerer  
Kühlmittelzufuhr siehe Katalog Zubehör Seite Z3.2 und Z4.1

#### Remarks:

Coolant supply through collet.  
Collet nuts and sealing rings for drills with internal  
coolant supply see catalog accessories page Z3.2 and  
Z4.1

Für Wkz.-Nr. For tool No.	Spannzange collet	Spannmutter Collet nut	Spannschlüssel Spanner wrenches
NG 16 / 415 E	218.570.____	10084	10005
NG 20 / 4541 E	218.710.____	10088	10006
NG 25 / 462 E	218.530.____	10085	10008
NG 32 / 467 E	218.540.____	10086	10009
NG 40 / 468 E	218.550.____	10087	10010

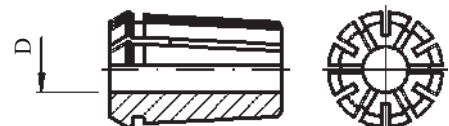

#### Bemerkungen:

\_: Bei Bestellung bitte Spanndurchmesser angeben.  
Bestellbeispiel: Spannzange NG 40 / 468 E,  
Spanndurchmesser 21,0 mm : 218.550.210

#### Remarks:

\_: Please list clamping diameter when ordering.  
Example of an order: Collet NG 40 / 468 E,  
clamping diameter 21,0 mm : 218.550.210

**Spannzangenaufnahme**  
für Spannzangen nach DIN 6345 Rubber-Flex

**Form E3**

Collet chuck

DIN 69 880

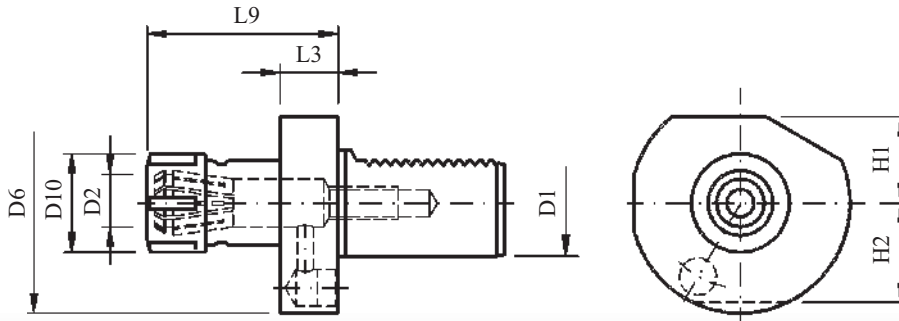

D1	D2	DIN Bezeichnung DIN-Designation	Artikel-Nr. Part No.	D6	D10 max.	H1	H2	L3	L9 max.	Spannzangen Collets	Rohrverschr. Coolant tubes
20	1,8 - 13	-	221.030.160	50	40	23	23	18	50	J440, J441 J443, J444	218.460.220
30	1,8 - 13	-	222.030.220	68	40	28	30	22	57		218.460.220
40	1,8 - 13	-	223.030.100	83	40	32,5	-	22	77		218.460.220

**Bemerkungen / Remarks:** Kühlmittelzufuhr durch Spannzange. / Coolant supply through collet

Einh.-Nr. Standard No.	Spannbereich Range (D1)	Spannzange Collet	Spannmutter Collet nut	Spannschlüssel Spanner wrenches
J 444	1,8 - 4,5	218.620.220	10092	10016
J 443	2,8 - 7	218.630.220	10092	10016
J 441	4,5 - 10	218.635.220	10092	10016
J 440	7 - 13	218.640.220	10092	10016



## Spannzangenaufnahme für Spannzangen nach DIN 6499 Schaublin

## Form E4

Collet chuck

DIN 69 880

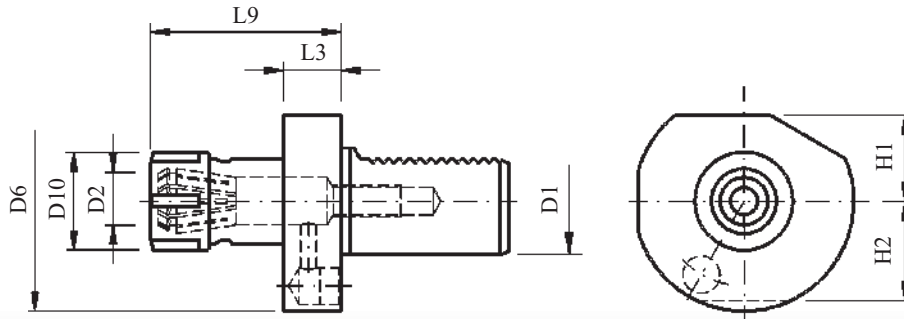

D1	D2	DIN-Bezeichnung DIN-Designation	Artikel-Nr. Part No.	D6	D10 max.	H1	H2	L3	L9 max.	Spannzangen collets	Rohrverschr. Coolant tubes
16	0,5-10	E4-16x16	220.000.220	40	28	18	18	14	45,5	ER 16	-
16	1-13	E4-16x20	220.000.150	40	34	18	18	14	44	ER 20	-
20	1-16	E4-20x25	221.040.090	50	42	23	23	18	57	ER 25	218.468.220
20	2-20	E4-20x32	221.035.220	50	50	23	23	18	62	ER 32	218.468.220
25	1-16	E4-25x25	227.040.090	58	42	25	25	18	57	ER 25	218.468.220
25	2-20	E4-25x32	227.035.220	58	50	25	25	18	62	ER 32	218.468.220
30	1-16	E4-30x25	222.040.090	68	42	28	30	22	57	ER 25	218.460.220
30	2-20	E4-30x32	222.035.220	68	50	28	30	22	75	ER 32	218.460.220
40	1-16	E4-40x25	223.040.220	83	42	32,5	-	22	63	ER 25	218.460.220
40	2-20	E4-40x32	223.035.220	83	50	32,5	-	22	75	ER 32	218.460.220
40	3-26	E4-40x40	223.045.220	83	63	32,5	-	22	75	ER 40	218.460.220
50	2-20	E4-50x32	224.035.220	94	50	35	-	30	75	ER 32	218.460.220
50	3-26	E4-50x40	224.045.220	94	63	35	-	30	63	ER 40	218.460.220
60	3-26	E4-60x40	225.045.220	123	63	42,5	-	30	75	ER 40	-

### Bemerkungen:

Kühlmittelzufuhr durch Spannzange.  
Spannmuttern und Dichtringe für Werkzeuge mit innerer  
Kühlmittelzufuhr siehe Katalog Zubehör Seite Z3.2 und Z4.1

### Remarks:

Coolant supply through collet.  
Collet nuts and sealing rings for drills with internal  
coolant supply see catalog accessories page Z3.2 and  
Z4.1

Nenngröße DIN term	Spannzange collet	Spannmutter Collet nut	Spannschlüssel Spanner wrenches
ER 20 / 428 E	218.615.____	10100	*
ER 25 / 430 E	218.600.____	10095	10011
ER 32 / 470 E	218.690.____	10097	10012
ER 40 / 472 E	218.610.____	10096	10013

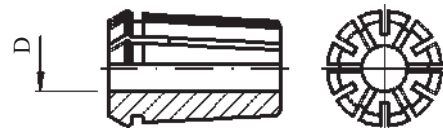

### Bemerkungen:

\_: Bei Bestellung bitte Spanndurchmesser angeben.  
Bestellbeispiel: Spannzange ER 40 / 472 E,  
Spanndurchmesser 21,0 mm : 218.610.210  
\* Spannmutter hat Sechskant für Gabelschlüssel.

### Remarks:

\_: Please list clamping diameter when ordering.  
Example of an order: Collet ER 40 / 472 E,  
clamping diameter 21,0 mm : 218.610.210  
\* Collet nut has a hexagon for fork wrenches.

# Spannzangenaufnahme

höhenverstellbar, für Spannzangen nach DIN 6499 Schaublin

**Form E4**

Collet chuck with height adjustment facility

**DIN 69 880**

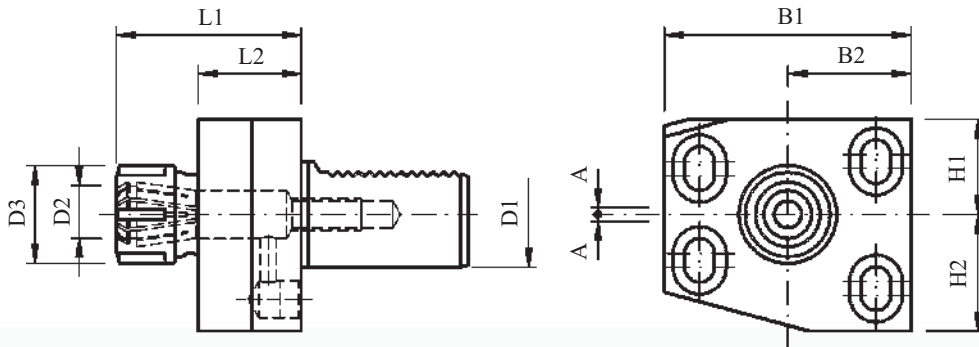

D1	D2	DIN Bezeichnung DIN-Designation		Artikel-Nr. Part No.	D3	H1	H2	B1	B2	L1	L2	A	Spannzangen Collets
20	1-16	-	*	231.110.090	42	24	29	55	30	70	-	2	ER 25
25	1-16	-	*	237.110.090	42	24	29	55	30	70	-	2	ER 25
30	1-16	-		232.110.090	42	27	33	70	35	56	30	2	ER 25
40	2-20	-	*	233.110.090	50	31	47	85	42,5	80	-	2	ER 32

**Bemerkungen:**

Kühlmittelezufuhr durch Spannzange.  
Spannmuttern und Dichtringe für Werkzeuge mit innerer Kühlmittelezufuhr siehe Katalog Zubehör Seite Z3.2 und Z4.1

\* Darstellung stimmt mit Werkzeug nicht überein.

**Remarks:**

Coolant supply through collet.  
Collet nuts and sealing rings for drills with internal coolant supply see catalog accessories page Z3.2 and Z4.1

\* Drawing not correspondent with tool

Nenngröße DIN term	Spannzange collet	Spannmutter Collet nut	Spannschlüssel Spanner wrenches
ER 25 / 430 E	218.600.____	10095	10011
ER 32 / 470 E	218.690.____	10097	10012

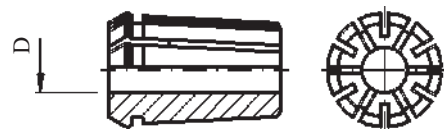

**Bemerkungen:**

\_\_\_: Bei Bestellung bitte Spanndurchmesser angeben.  
Bestellbeispiel: Spannzange ER 25 / 430 E,  
Spanndurchmesser 14,0 mm : 218.600.140

**Remarks:**

\_\_\_: Please list clamping diameter when ordering.  
Example of an order: Collet ER 25 / 430 E,  
clamping diameter 14,0 mm : 218.600.140



# Morsekegelaufnahme

# Form F1

Morse taper holder

DIN 69 880

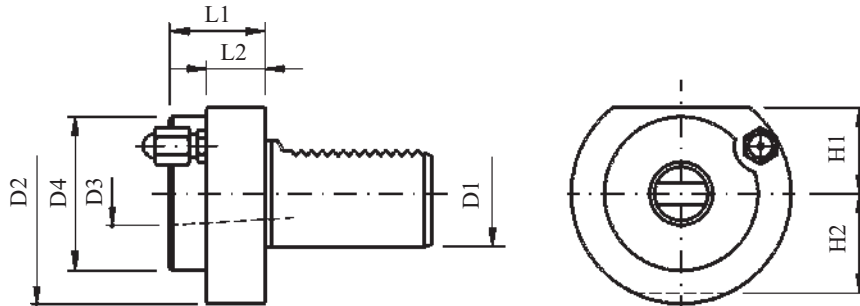

D1	(D3) MK-DK	DIN-Bezeichnung DIN-Designation	Artikel-Nr. Part No.	D2	D4	H1	H2	L1	L2	Rohrverschr. Coolant tubes
20	1	F20-MK-DK1	201.125.150	50	-	23	23	23	-	218.825.220
20	2	F20-MK-DK2	201.130.220	50	-	23	23	87	-	218.468.220
25	1	F25-MK-DK1	207.125.220	58	-	25	25	23	-	-
25	2	F25-MK-DK2	207.130.150	58	-	25	25	27	-	-
30	1	F30-MK-DK1	202.125.150	68	-	28	30	27	-	218.825.220
30	2	F30-MK-DK2	202.130.150	68	-	28	30	27	-	218.825.220
30	3	F30-MK-DK3	202.135.220	68	58	28	30	55	40	218.825.220
40	2	F40-MK-DK2	203.130.150	83	55	32,5	-	36	22	218.825.220
40	3	F40-MK-DK3	203.135.150	83	58	32,5	-	36	22	218.825.220
40	4	F40-MK-DK4	203.140.150	83	68	32,5	-	80	22	218.460.220
50	2	F50-MK-DK2	204.130.150	98	55	35	-	36	30	218.825.220
50	3	F50-MK-DK3	204.135.150	98	58	35	-	36	30	218.825.220
50	4	F50-MK-DK4	204.140.150	98	68	35	-	50	30	218.460.220
60	2	F60-MK-DK2	205.130.220	123	55	42,5	-	36	30	218.825.220
60	3	F60-MK-DK3	205.135.150	123	58	42,5	-	36	30	218.825.220
60	4	F60-MK-DK4	205.140.150	123	68	42,5	-	50	30	218.825.220
60	5	F60-MK-DK5	205.145.150	123	98	42,5	-	63	30	218.460.220

**Bemerkungen:**

Innere Kühlmittelzufuhr für Kühlkanalbohrer nach DIN 228 Form BK (Kühlmittelzufuhr radial im Einstich).

**Remarks:**

For drills with coolant through the tool to DIN 228 Form BK.

# Klemmring

# Form Z1

Clamping ring

DIN 69 880

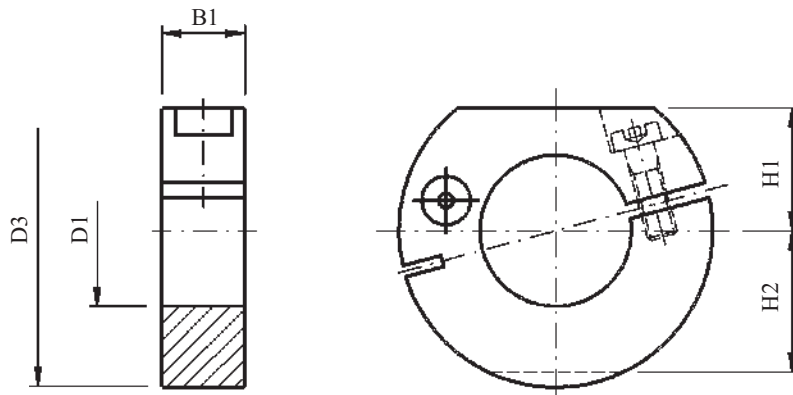

D1	DIN-Bezeichnung DIN-Designation	Artikel-Nr. Part No.	D3	H1	H2	B1
20	Z1-20	201.020.150	50	23	23	16
30	Z1-30	202.020.150	68	28	30	22
40	Z1-40	203.030.150	83	32,5	-	22
50	Z1-50	204.040.150	98	35	-	30
60	Z1-60	205.020.150	123	42,5	-	30

# Schutzstopfen

# Form Z2

Blanking plug

DIN 69 880

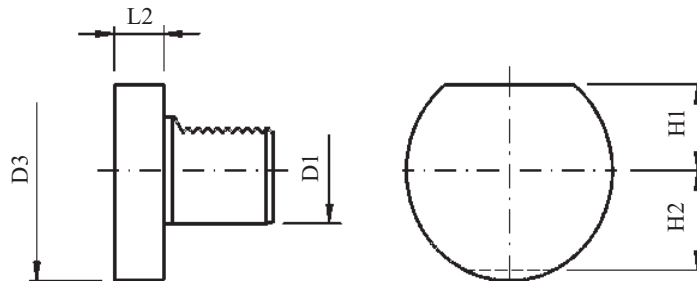

D1	DIN-Bezeichnung DIN-Designation	Artikel-Nr. Part No.	D3	H1	H2	L2	Material material
16	Z2-16	210.500.150	40	18	-	13	Stahl / steel
16	Z2-16	210.500.001	40	18	-	13	Kunststoff / plastic
20	Z2-20	211.500.150	50	23	23	16	Stahl / steel
20	Z2-20	211.500.001	50	23	23	16	Kunststoff / plastic
25	Z2-25	217.500.150	58	25	25	16	Stahl / steel
25	Z2-25	217.500.001	58	25	25	16	Kunststoff / plastic
30	Z2-30	212.500.150	68	28	30	16	Stahl / steel
30	Z2-30	212.500.001	68	28	30	16	Kunststoff / plastic
40	Z2-40	213.500.150	83	32,5	-	20	Stahl / steel
40	Z2-40	213.500.001	83	32,5	-	20	Kunststoff / plastic
50	Z2-50	214.500.150	98	35	-	20	Stahl / steel
50	Z2-50	214.500.001	98	35	-	20	Kunststoff / plastic
60	Z2-60	215.500.150	123	42,5	-	20	Stahl / steel
60	Z2-60	215.500.001	123	42,5	-	20	Kunststoff / plastic

# Bohrstangenhalter *geschlitzt*

Boring bar holder

DIN 69 880

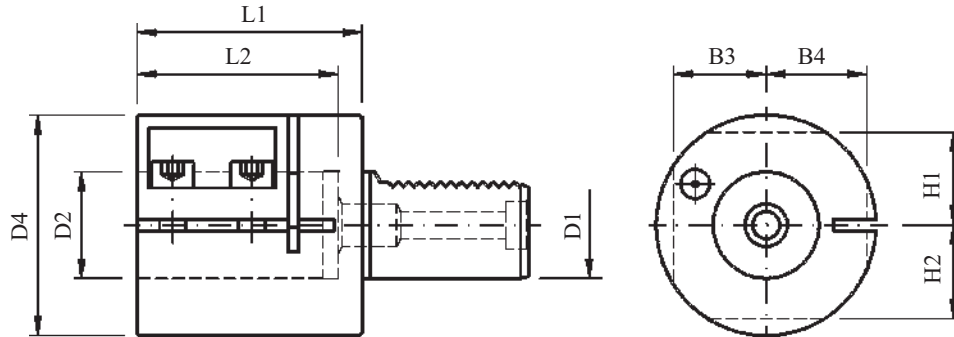

D1	D2 <sup>H7</sup>	Artikel-Nr. Part No.	D4	L1	L2	H1	H2	B3	B4
30	32	212.050.090	68	70	61				
40	32	7.040.260	83	85	75				
40	40	213.055.090	83	85	75				
40	50	213.055.159	-	85	75	41	41	41	43

# Reduzierbuchsen

Bushing

Für Wkz.-Nr. For tool No.	212.050.090	213.055.090
D1 <sub>h6</sub>	32	40
L1	65	72
D2 <sup>H6</sup>	Artikel-Nr. Part No.	Artikel-Nr. Part No.
8	218.380.220	218.446.220
10	218.381.220	218.447.220
12	218.382.220	218.448.220
16	218.383.220	218.449.220
20	218.384.220	218.450.220
25	218.385.220	218.451.220
30	-	218.452.220
32	-	218.453.220

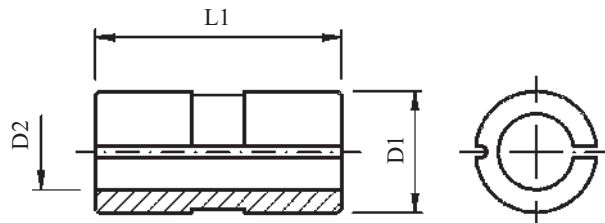

# Kurzbohrfutter

Short drilling chuck for reversible operation

DIN 69 880

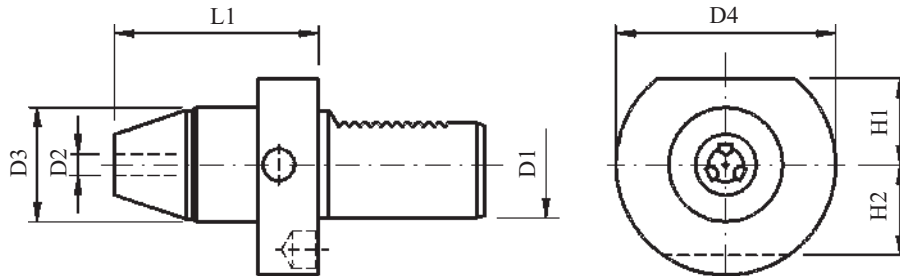

D1	D2	Artikel-Nr. Part No.	D3	D4	H1	H2	L1
20	0 - 10	241.020.220	50	50	-	-	38
20	1 - 13	241.021.220	43	50	-	-	89
25	0,5 - 8	247.020.220	36	58	-	-	68
30	1 - 13	242.022.220	43	68	28	31	89
40	1 - 13	243.022.220	43	83	32,5	-	85
40	2,5 - 16	243.027.220	56	83	32,5	-	100
50	2,5 - 16	244.025.220	56	98	35	-	100
60	2,5 - 16	245.020.220	56	123	42,5	-	100

**Bemerkungen / Remarks:**

Kühlmittelezufuhr durch das Zentrum des Bohrfutters.  
Coolant supply through the center of the drilling chuck.

**Werkstoffanschlag mitlaufend**

Revolving stock stop

DIN 69 880

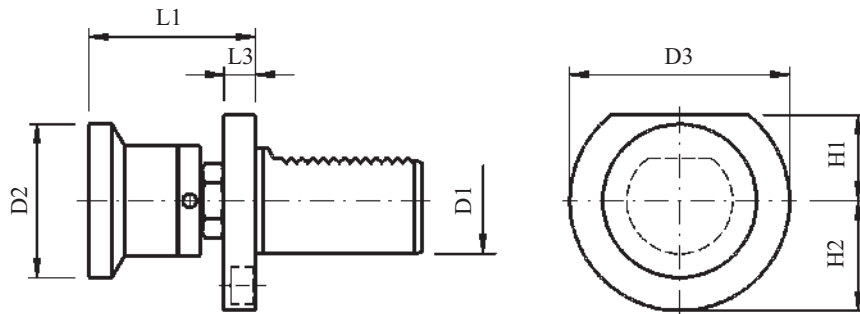

D1	D2	Artikel-Nr. Part No.	D3	H1	H2	L1	L3
20	45	201.040.160	50	23	23	40 - 70	8
25	45	207.045.100	58	25	25	40 - 70	15
30	58	202.040.090	70	28	30	61 - 97	11
30	26	202.045.100	68	28	30	62 - 95	20
40	58	203.040.220	83	32,5	-	62 - 95	12

# Schneideisenhalter *ausziehbar*

Extensible die holder

DIN 69 880

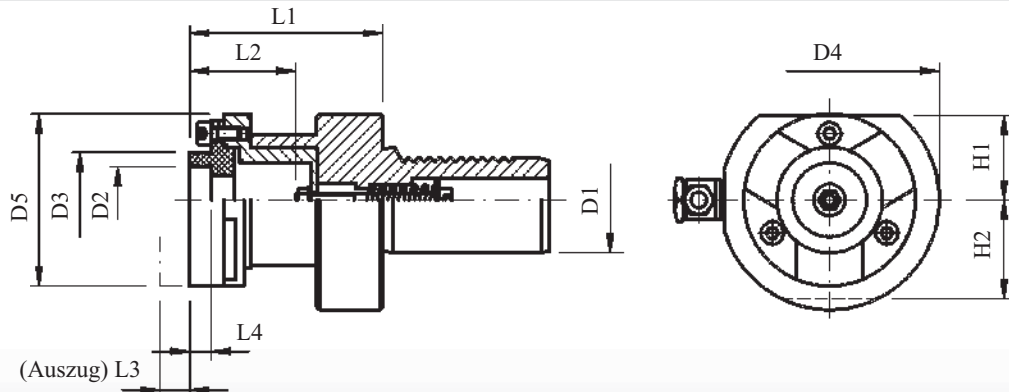

D1	Artikel-Nr. Part No.	D3	D4	D5	H1	H2	L1	L3
20	241.335.220	18	50	38	23	23	35	6
30	242.335.220	40	68	65	28	30	57	12
40	243.335.220	40	83	65	32,5	-	62	12

# Einsätze für Schneideisenhalter

Inserts for extensible holder

Artikel-Nr. Part No.	Für Gewinde nach DIN 13 for threads to DIN 13	Für Feingewinde nach DIN 13 for fine threads to DIN 13	Abmessungen dimensions		max. Gewindelänge max. thread length		
			Aussen-Ø D2	L4	241.335.220 L2	242.335.220 L2	243.335.220 L2
113.406.220	M1 - M2,6	-	16	5	18	-	-
113.408.220	M3 - M4	M3 - M6	20	6	24,2	-	-
113.410.220	M 4,5 - M6	M6	20	7	24,2	-	-
113.412.220	M7 - M9	M7 - M9	25	9	26,2	-	-
113.414.220	M10 - M11	M10 - M11	30	11	27,2	-	-
115.406.220	M1 - M2,6	-	16	5	-	37	38
115.408.220	M3 - M4	M3 - M6	20	5	-	37	38
115.410.220	M4,5 - M6	M6	20	7	-	39	40
115.412.220	M7 - M9	M7 - M9	25	9	-	41	42
115.414.220	M10 - M11	M10 - M11	30	11	-	38	39
115.416.220	-	M12 - M14	38	10	-	42	43
115.418.220	M12 - M14	-	38	14	-	46	47
115.436.220	-	M16 - M20	45	14	-	51	52
115.438.220	M16 - M20	-	45	18	-	55	56
115.440.220	-	M22 - M24	55	16	-	53	54
115.442.220	M22 - M24	-	55	22	-	59	60

Bemerkungen / Remarks: Schneideisen nicht im Lieferumfang enthalten. / Extensible not in product range.

# Zentrierspitze mitlaufend für Zentriereinsätze

Revolving center point with inserts for centering inserts

DIN 69 880

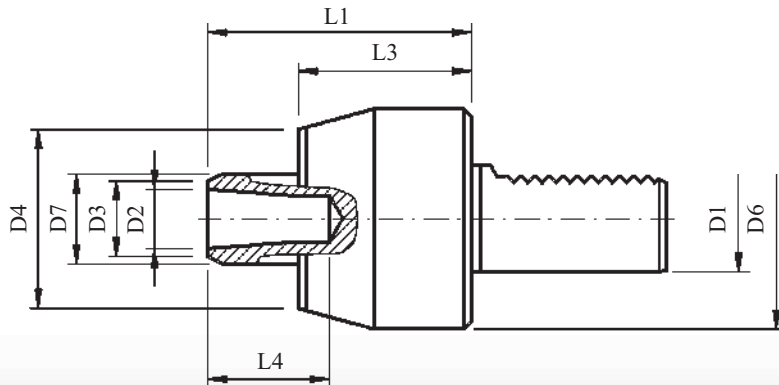

D1	D2 Kegel 1:10	Artikel-Nr. Part No.	D3	D4	D6	D7	L1	L3	L4
20	7	241.201.220	18	41	50	12	73	64	20
30	12	242.201.220	22	47	67	18	88	76	24
40	12	243.201.220	32	56	83	18	111	96	24

# Zentriereinsatz

Centering inserts

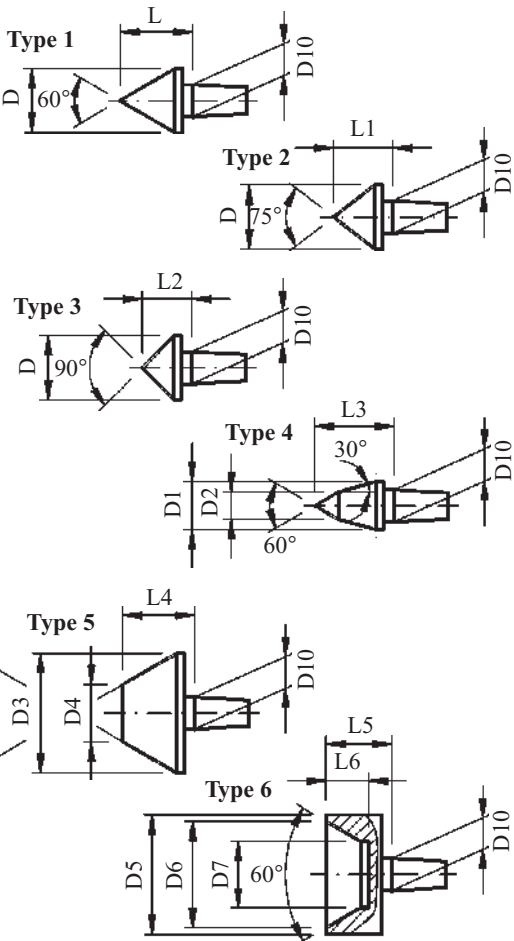

Schaft-Ø	20	30	40
D	16	20	24
D1	14	18	18
D2	6	8	8
D3	25	35	45
D4	10	15	25
D5	25	35	45
D6	20	30	40
D7	10	15	25
D10 Kegel 1:10	7	12	12
L	20	24	27,5
L1	17	19,5	22,5
L2	14,5	16,5	19
L3	25	30	30
L4	21	26	27
L5	18	24	25
L6	11	16	16
Type	Artikel-Nr. Part No.	Artikel-Nr. Part No.	Artikel-Nr. Part No.
1	218.916.021	218.916.031	218.916.041
2	218.916.022	218.916.032	218.916.042
3	218.916.023	218.916.033	218.916.043
4	218.916.024	218.916.034	218.916.044
5	218.916.025	218.916.035	218.916.045
6	218.916.026	218.916.036	218.916.046
Austreiber	218.916.020	218.916.030	218.916.040



# Pendelhalter mit innerer Kühlmittelzufuhr

Floating holder with internal coolant supply

DIN 69 880

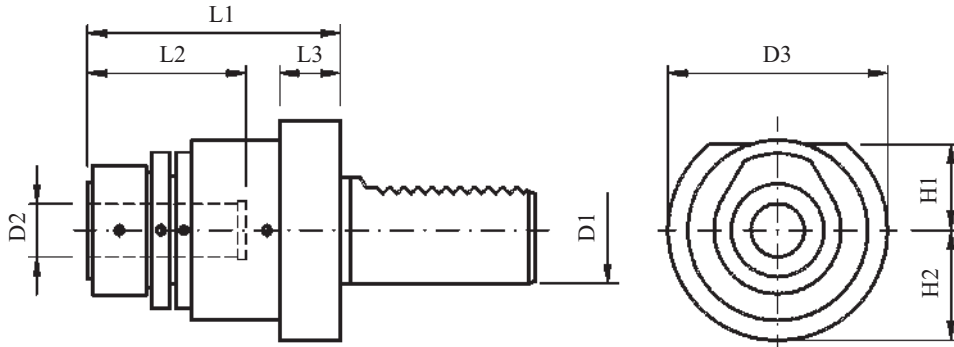

D1	D2 <sup>H7</sup>	Artikel-Nr. Part No.	D3	H1	H2	L1	L2	L3
30	25	242.310.220	68	28	30	95	60	23
40	25	243.310.220	83	32,5	-	95	60	23
50	25	244.310.220	98	35	-	95	60	23
60	25	245.310.220	123	42,5	-	95	60	23

# Reduzierbuchsen

Bushing

Spann.Ø D1	Artikel-Nr. Part No.	D2	L1	L2
16	218.242.220	25	60	42
20	218.241.220	25	60	40

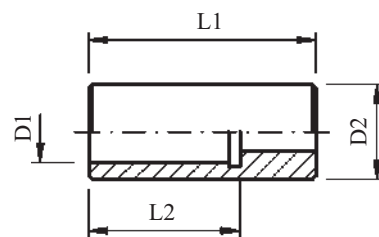

## Pendelhalter mit äusserer Kühlmittelzufuhr

Floating holder with external coolant supply

DIN 69 880

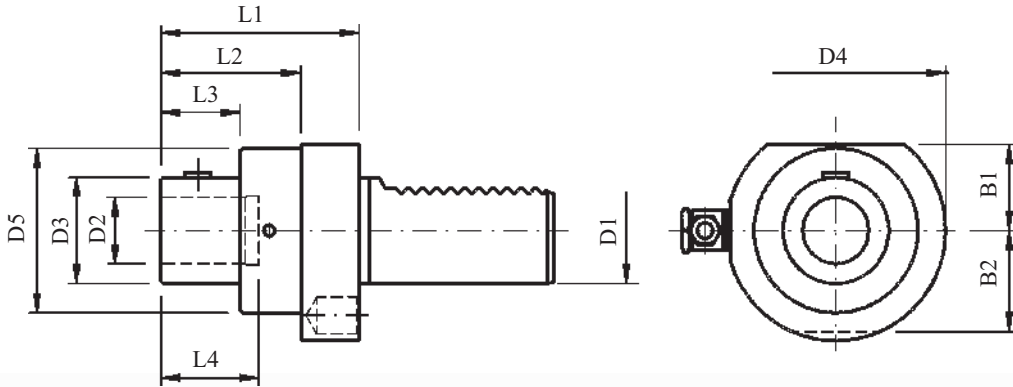

D1	D2 <sup>H6</sup>	Artikel-Nr. Part No.	D3	D4	D5	B1	B2	L1	L2	L3	L4
20	18	241.380.220	30	50	50	-	-	60	42,5	16	22

## Reduzierbuchsen

Bushing

Für Wkz.-Nr. For tool No.	241.380.220		
D1 <sub>h6</sub>	18		
L1	26		
D2 <sup>H6</sup>	Artikel-Nr. Part No.	D2 <sup>H6</sup>	Artikel-Nr. Part No.
2,2	-	7,1	218.854.220
2,5	-	8	218.855.220
2,8	-	9	218.856.220
3	-	10	118.220.220
3,5	218.848.220	11	-
4	218.849.220	12	-
4,5	218.850.220	12,5	118.227.220
5	218.851.220	14	118.224.220
5,6	218.852.220	16	118.226.220
6	-	18	-
6,3	218.853.220	20	-

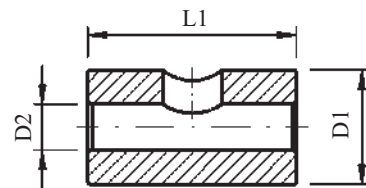

# Pendelhalter mit äusserer Kühlmittelzufuhr

Floating holder with external coolant supply

DIN 69 880

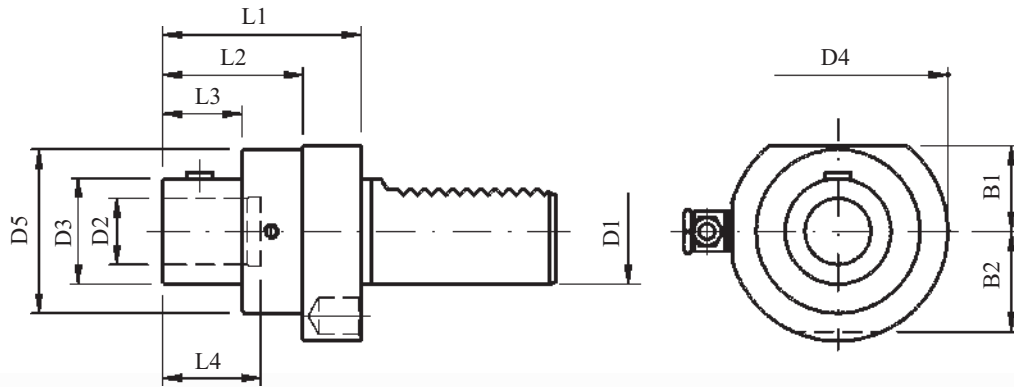

D1	D2 <sup>H6</sup>	Artikel-Nr. Part No.	D3	D4	D5	B1	B2	L1	L2	L3	L4
30	25	242.380.220	40	68	62	28	30	75	53	21	32
40	25	243.380.220	40	83	62	32,5	-	75	53	21	32
50	25	244.380.220	40	98	62	35	-	75	53	21	32

# Reduzierbuchsen

Bushing

Für Wkz.-Nr. For tool No.	242.380.220	243.380.220	244.380.220
D1 <sub>h6</sub>		25	
L1		36	
D2 <sub>h6</sub>	Artikel-Nr. Part No.	D2 <sup>H6</sup>	Artikel-Nr. Part No.
2,2	218.246.220	7	118.237.220
2,5	218.471.220	8	118.238.220
2,8	218.247.220	9	118.239.220
3	218.473.220	10	118.240.220
3,5	218.248.220	11	118.241.220
4	118.234.220	12	118.242.220
4,5	218.249.220	12,5	218.476.220
5	118.235.220	14	118.244.220
5,6	218.474.220	16	118.246.220
6	118.236.220	18	118.248.220
6,3	218.475.220	20	118.250.220

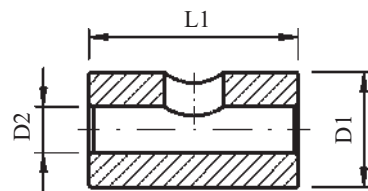

# Abstechhalter höhenverstellbar

Cut-off tool holder, height adjustable

DIN 69 880

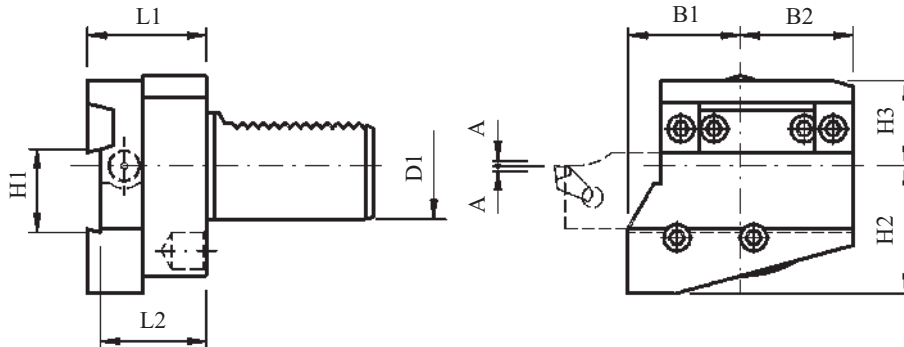

D1	Ausführung Execution	Artikel-Nr. Part No.	B1	B2	H1	H2	H3	L1	L2	A	
20	Form A	211.650.160	28	25	26	30	25	40	35	1,5	
20	Form C	211.655.220	28	25	26	30	25	40	35	1,5	
25	Form A	217.680.220	28	25	26	30	25	40	35	2	*
25	Form C	217.665.220	28	25	26	30	25	40	35	2	*
30	Form A	212.680.220	35	35	26	38	28	49	44	2	*
30	Form B	212.675.220	35	35	26	38	28	49	44	2	*
30	Form C	212.665.220	35	35	26	38	34	49	44	2	*
30	Form D	212.670.220	35	35	26	38	34	49	44	2	*
40	Form A	213.630.220	42,5	42,5	32	48	32	49	44	2	*
40	Form B	213.635.220	42,5	42,5	32	48	32	49	44	2	*
40	Form C	213.640.220	42,5	42,5	32	48	32	49	44	2	*
40	Form D	213.645.220	42,5	42,5	32	48	32	49	44	2	*

**Bemerkungen / Remarks:**

- Für Iscar und Coromant Schneidträger.  
For Iscar and Coromant cut-off tool.
- \* Für Kühlmittelzufuhr durch den Schneidträger.  
\* For coolant supply through the cut-off tool.

Form A

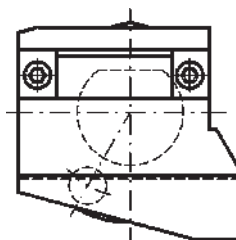

Form B

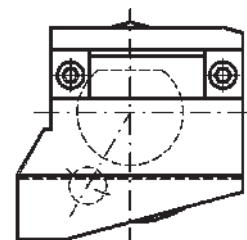

Form C

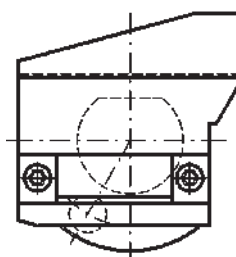

Form D

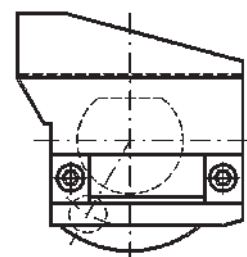

**Gewindebohrhalter mit Längenausgleich**  
**auf Zug und Druck für Spannzangen nach DIN 6499**

Tap holder with tension and traction compensation

**DIN 69 880**

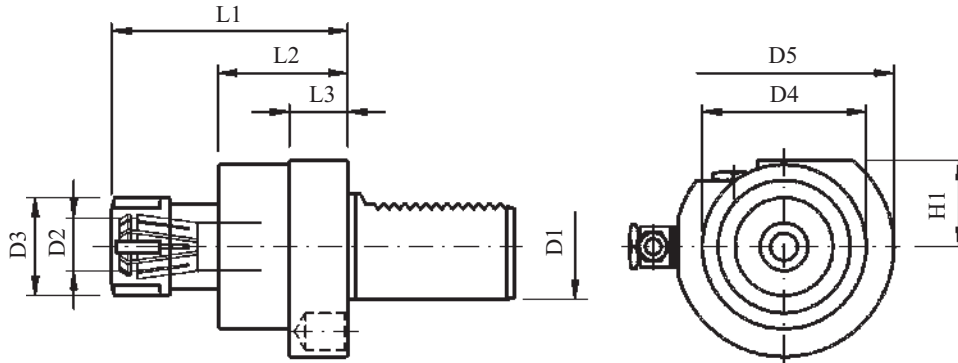

D1	D2	Artikel-Nr. Part No.	D3	D4	D5	H1	L1	L2	L3	Spannzangen collets	Längenausgleich Zug/Druck tension/traction comp.
20	0,5-10	221.390.220	28	45	50	23	65	40	18	ER 16	6 / 1,5
25	0,5-10	227.390.220	28	45	58	25	65	40	18	ER 16	6 / 1,5
30	1-16	222.390.220	42	62	68	28	90	54	22	ER 25	8 / 2
40	1-16	223.390.220	42	62	83	32,5	85	49	22	ER 25	8 / 2
50	1-16	224.390.220	42	62	98	35	85	49	22	ER 25	8 / 2

**Bemerkungen:**

Mitnehmer für Gewindebohrer siehe Katalog Zubehör für Werkzeughalter Seite Z10.1

**Remarks:**

Drivers for tap see catalog accessories for tool holder page Z10.1

Nenngröße DIN term	Spannzange Collet	Spannmutter Collet nut	Spannschlüssel Spanner wrenches
ER 16 / 426 E	218.605.____	10099	*
ER 25 / 430 E	218.600.____	10095	10011

**Bemerkungen:**

\_\_\_: Bei Bestellung bitte Spanndurchmesser angeben.  
 Bestellbeispiel: Spannzange ER 16 / 426 E,  
 Spanndurchmesser 10,0 mm : 218.605.100  
 \* Spannmutter hat Sechskant für Gabelschlüssel.

**Remarks:**

\_\_\_: Please list clamping diameter when ordering.  
 Example of an order: Collet ER 16 / 426 E,  
 clamping diameter 10,0 mm : 218.605.100  
 \* Collet nut has a hexagon for fork wrenches.

# Greiferfutter

Bar puller

DIN 69 880

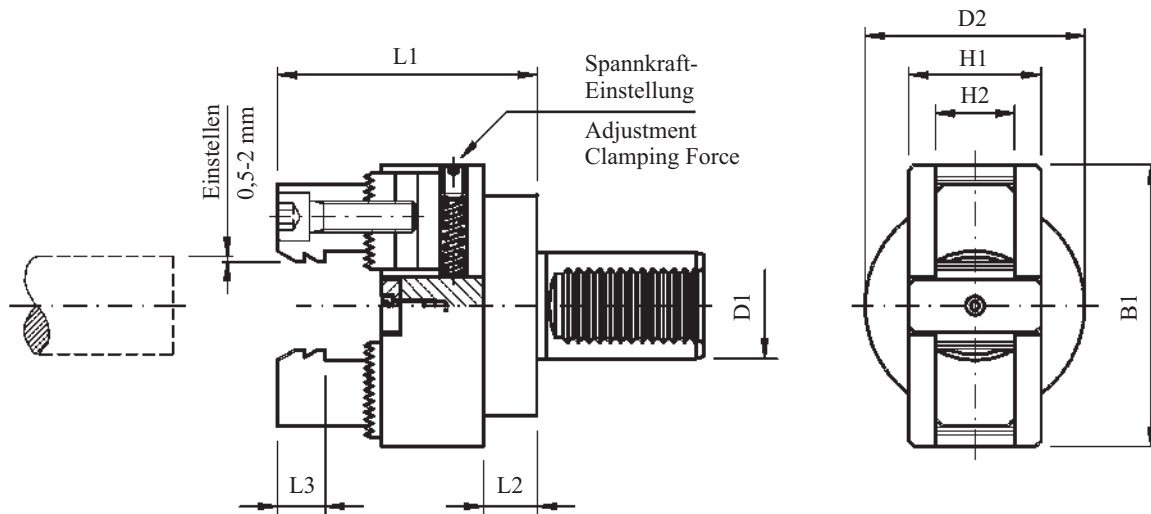

D1	Artikel-Nr. Part No.		Stangen-Ø Raw material Ø	Einstellbare Spannkraft Adjustm. clamping force	L1	L2	L3	B1	D2	H1	H2
20	241.200.220	*	4 - 68	20 - 120	89,5	16	18	106	50	50	30
25	247.200.220	*	4 - 68	20 - 120	90	16,5	18	106	58	50	30
30	242.200.220	*	4 - 68	20 - 120	90	16,5	18	106	68	50	30
40	243.200.220	*	4 - 68	20 - 120	98	16,5	18	106	83	50	30
50	244.200.220	*	4 - 68	20 - 120	116	42,5	18	106	98	50	30

**Bemerkungen / Remarks:**

\* geliefert mit 1 Satz Backen für Stangen Ø 15 - 68

\* scope of delivery 1 set jaw for raw material Ø 15 - 68

# Satz Backen für Greiferfutter

Jaw for bar puller

Artikel-Nr. Part No.	Stangen-Ø Raw material Ø
218.985.220	4 - 20
218.986.220	15 - 68

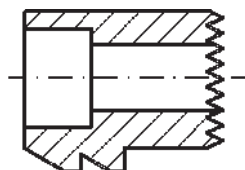

# Prüfdorn

Test mandrel

DIN 69 880

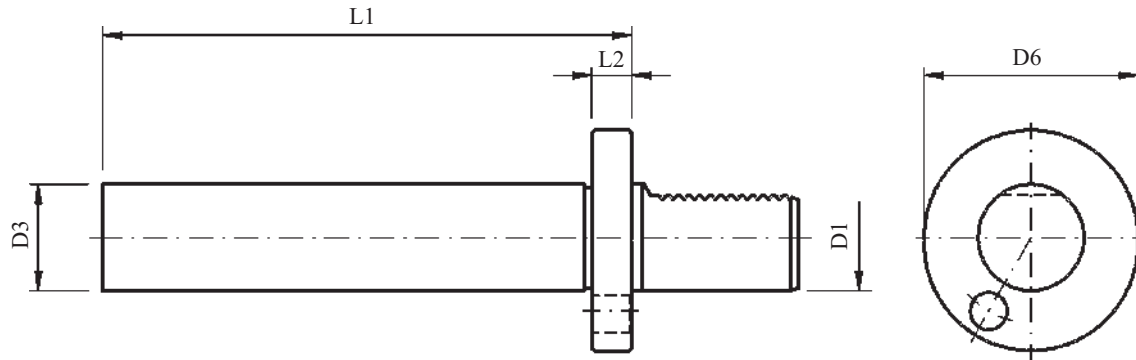

D1	D3 h5	Artikel-Nr. Part No.	D6	L1	L2
16	30	240.204.220	40	120	15
20	40	241.204.220	50	150	15
25	40	247.204.220	58	150	15
30	40	242.204.220	68	200	15
40	40	243.204.220	83	200	15
50	40	244.204.220	98	200	15
60	40	245.204.220	123	200	15



ESA Eppinger GmbH · Breitwiesen 2-8 · D-73770 Denkendorf  
Telefon + 49 (0) 711 934 934-0 · Telefax + 49 (0) 711 934 934-1  
E-Mail: [info@eppinger.de](mailto:info@eppinger.de) · Internet: <http://www.eppinger.de>